

OCF10-M62001EN

Introduction

1. This parts catalog for 2YM15 is published as a revised edition.

	Date of issue	Remarks
First edition	Sep., 2004	No need
1st revised edition	Nov., 2018	

2. This parts catalog does not contain the technical data needed for maintenance service.

3. The illustrations used in this parts catalog have been simplified for clarity.

4. The contents of this parts catalog are subject to change without notice.

5. Be sure to use only Yanmar genuine parts for repairs. If imitation parts are used, it may cause engine defects.

Contents

OCF10-M62001

Fig. No.	Fig. Name	Fig. No.	Fig. Name
2YM15		23.	FUEL PIPE & FUEL FILTER
1.	CYLINDER BLOCK	46.	(23A)WATER SEPARATOR
2.	GEAR HOUSING	24.	FUEL TANK(OPTIONAL)
3.	FLYWHEEL HOUSING & OIL SUMP	25.	BRACKET(CABLE)
4.	MOUNTING FOOT	26.	CLUTCH
5.	LABEL	27.	CLUTCH REMOTE CONTROL
6.	CYLINDER HEAD & BONNET	28.	COUPLING(OPTIONAL)
7.	AIR INTAKE SILENCER	29.	STARTER MOTOR
8.	MIXING ELBOW	30.	GENERATOR(HITACHI/60A)(UP TO SEP. 2010)
9.	CAMSHAFT & DRIVING GEAR	31.	GENERATOR(HITACHI/80A)(UP TO E/#E5887)
10.	CRANKSHAFT & PISTON	37.	(31A)GENERATOR(VALEO)(FROM E/#E5888)
11.	DIPSTICK	42.	(31B)GENERATOR(INNER PARTS)
12.	LUB. OIL SYSTEM	32.	COVER(V-BELT)
13.	COOLING PUMP(SEA WATER)(TO E/#E6835)	33.	WIRE HARNESS & RELAY
41.	(13A)COOLING PUMP(SEA WATER)(FROM E/#E6836)	43.	(33A)WIRE HARNESS (2-PANEL SPEC.)
14.	COOLING PUMP(FRESH WATER)	44.	(33B)ELECTRIC PARTS
15.	COOLER(FRESH WATER)	34.	INSTRUMENT PANEL(B-TYPE)(OPTIONAL)
16.	COOLING PIPE(SEA WATER)	35.	TOOL
17.	BILGE PUMP(STANDARD)(OPTIONAL)(TO APR. 2004)	36.	GASKET SET(OPTIONAL)
18.	BILGE PUMP(DELUXE)(OPTIONAL)(TO APR. 2004)	38.	INSTRUMENT PANEL(MEDALLION)(FROM JAN. 2012)
40.	(18A)BILGE PUMP(OPTIONAL)(FROM MAR. 2004)	39.	COMBINATION OF GENERATOR, WIRE HARNESS, AND PANEL
19.	FUEL INJECTION PUMP	45.	PROPELLER NUT
20.	GOVERNOR		
21.	FUEL FEED PUMP		
22.	FUEL INJECTION VALVE & FUEL INJECTION PIPE		

Fig.1. CYLINDER BLOCK

(A)=2YM15
(B)=
(C)=

(D)=
(E)=
(F)=

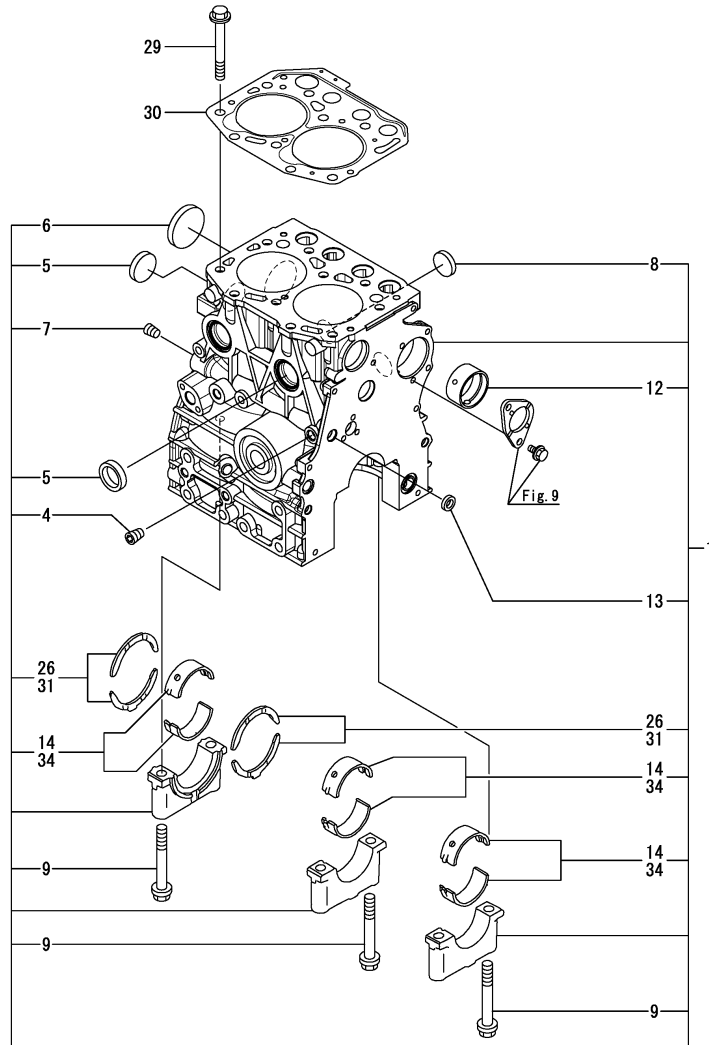

No.	Lev.	Parts No.	Description	Q'ty						I	R
				(A)	(B)	(C)	(D)	(E)	(F)		
1	1	719415-01560	BLOCK ASSY, CYLINDER	1							
4	3	124060-01050	PLUG, PT1/8	1							
5	3	105311-01090	PLUG, 30	3							
6	3	119623-01250	PLUG, 45	1							
7	3	124160-01910	PLUG, PT1/4	1							
8	3	119285-01990	PLUG, 25	2							
9	3	119620-02020	BOLT, METAL CAP	6							
12	3	119717-02410	BUSH, CAMSHAFT	1							
12-1	3	119717-02411	BUSH, CAMSHAFT	1							N
(A=*2006.06.)											
13	3	27241-120000	PLUG, 12	1							
14	2	719717-02900	METAL ASSY, MAIN	3							1
26	2	119717-02930	METAL ASSY, THRUST	2							
29	1	119515-01200	BOLT, CYLINDER HEAD	10							
30	1	119415-01330	GASKET, HEAD	1							
31	1	119810-02940	METAL ASSY, 0.25 OS	2							2
31-1	1	119810-02941	METAL ASSY, 0.25 OS	2							N 2
(A=*2006.06.)											
34	1	719717-02910	BEARING ASSY, MAIN	3							3
34-1	1	719717-02911	METAL ASSY, MAIN .25	3							N 3
(A=*2006.06.)											

Remarks

- (1) Spare parts.
- (2) Over-sized (O.S.=0.25) parts.
- (3) Under-sized (U.S.=0.25) parts.

Fig.2. GEAR HOUSING

(A)=2YM15

(B)=

(C)=

(D)=

(E)=

(F)=

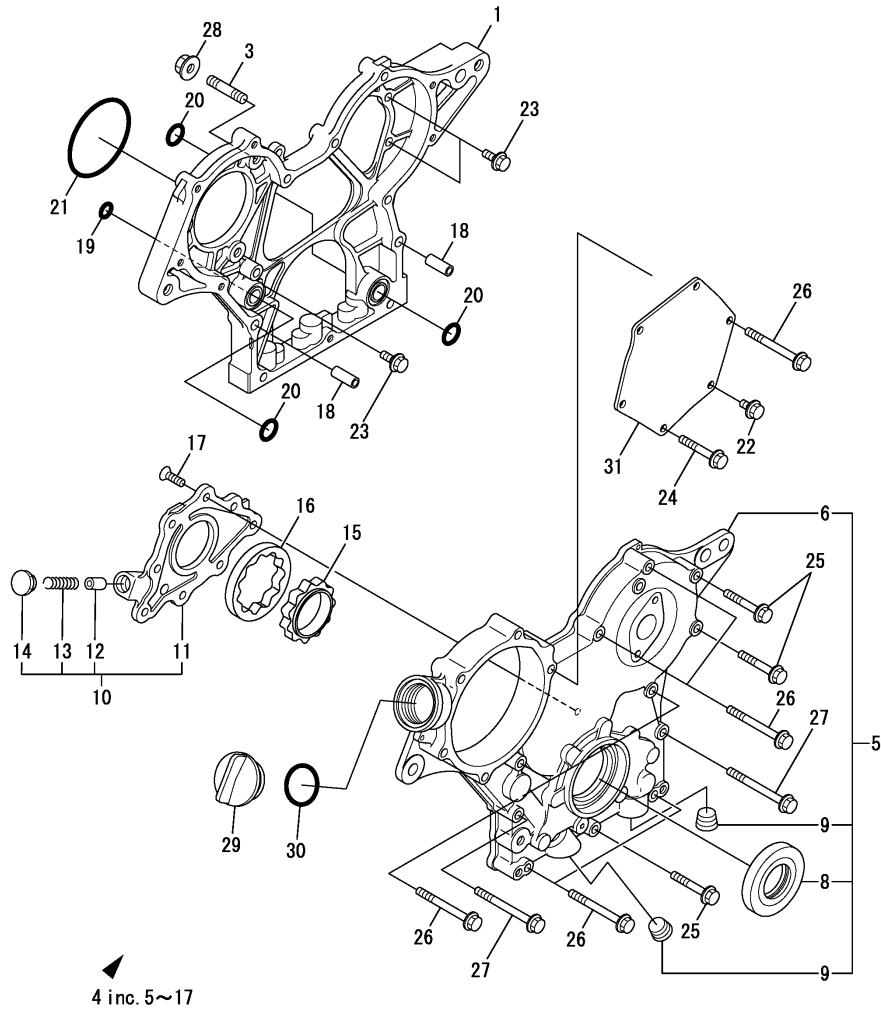

No.	Lev.	Parts No.	Description	Q'ty						I	R
				(A)	(B)	(C)	(D)	(E)	(F)		
1	1	119717-01501	CASE, GEAR	1							
3	1	119717-01570	STUD	3							
4	1	119717-01590	COVER ASSY, CASE	1							
5	2	719717-01500	COVER ASSY, CASE	1							
6	3	119717-01521	COVER, GEAR CASE	1							
8	3	119620-01800	SEAL, OIL HTC456208	1							
9	3	23876-030000	PLUG, R03	2							
10	2	119717-32100	COVER ASSY, PUMP	1							
11	3	119717-32080	COVER, OIL PUMP	1							
12	3	129900-32130	VALVE, RELIEF	1							
13	3	129001-32320	SPRING	1							
14	3	129001-32330	PLUG	1							
15	2	119717-32110	ROTOR, INNER	1							
16	2	119717-32120	ROTOR, OUTER	1							
17	2	119802-32130	SCREW, M6X16	8							
18	1	119660-01911	PIPE, KNOCK 6X17	4							
19	1	119624-32040	O-RING, P12.0	1							
20	1	119717-32050	O-RING, P17.0	3							
21	1	121850-51960	O-RING, FUEL PUMP	1							
22	1	26106-060122	BOLT, M6X 12 PLATED	1							
23	1	26106-060162	BOLT, M6X 16 PLATED	4							
24	1	26106-060402	BOLT, M6X 40 PLATED	4							
25	1	26106-060402	BOLT, M6X 40 PLATED	3							
26	1	26106-060602	BOLT, M6X 60 PLATED	7							
27	1	26106-060652	BOLT, M6X 65 PLATED	2							
28	1	26306-080002	NUT, M8	3							
29	1	124160-01751	CAP, FILLER	1							
30	1	24311-000320	O-RING, 1AP32.0	1							
31	1	119717-01750	COVER, PUMP	1							

Fig.3. FLYWHEEL HOUSING & OIL SUMP

(A)=2YM15
(B)=
(C)=

(D)=
(E)=
(F)=

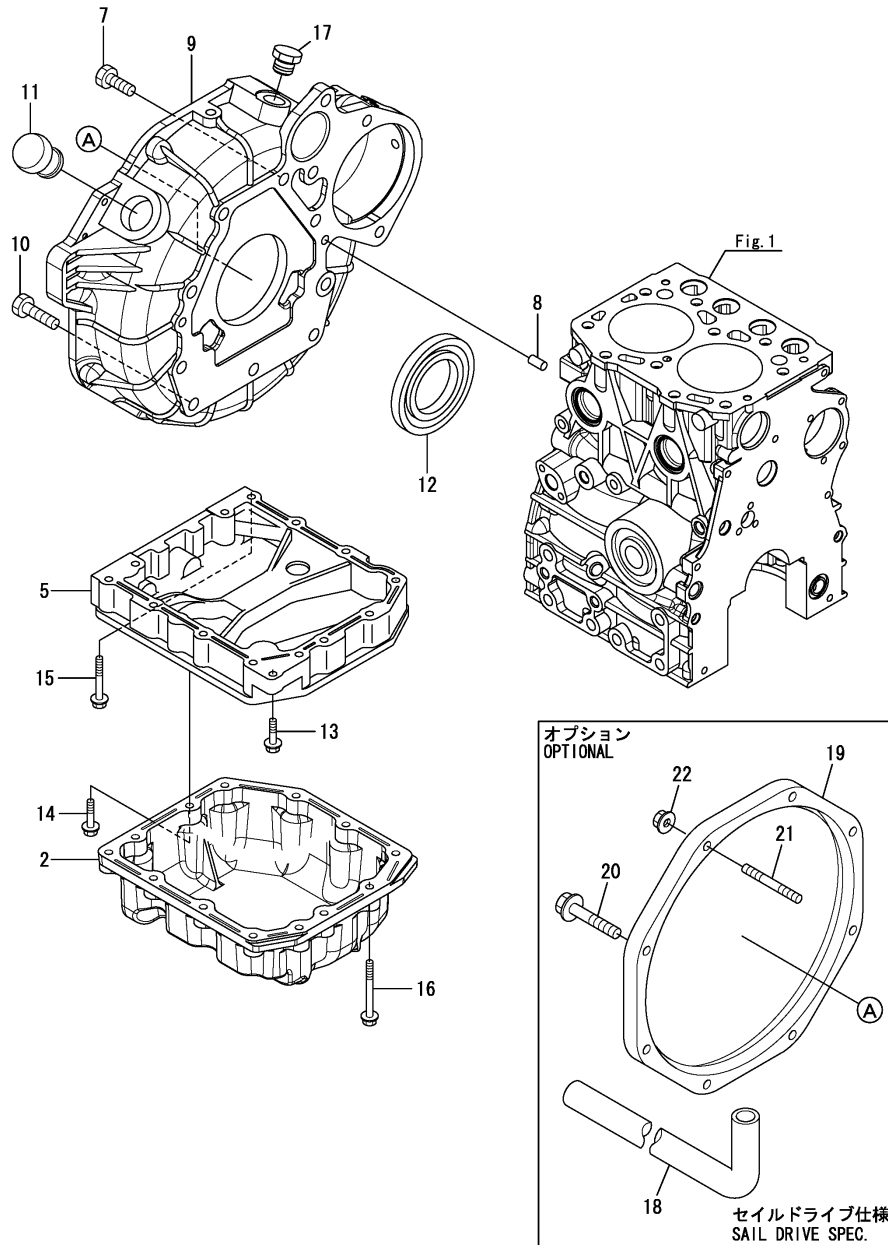

No.	Lev.	Parts No.	Description	Q'ty						I	R
				(A)	(B)	(C)	(D)	(E)	(F)		
2	2	128790-01700	OIL PAN	1							
5	1	119415-01720	SPACER, OIL PAN	1							
7	1	26206-100252	BOLT, M10X 25 PLATED	8							
8	1	129100-01580	PIN, PARALLEL 8X16	2							
9	1	128990-01650	HOUSING, FLYWHEEL	1							
10	1	121120-01620	BOLT, M10X28	3							
10-1	1	26206-100302	BOLT, M10X 30 PLATED	3							R
		(A=*2009.08.)									
11	1	119620-01750	CAP, WHEEL COVER	1							
12	1	124085-02220	SEAL, METAL HOUSING	1							
13	1	26106-060252	BOLT, M6X 25 PLATED	1							
14	1	26106-060282	BOLT, M6X 28 PLATED	1							
15	1	26106-060452	BOLT, M6X 45 PLATED	1							
16	1	26106-060602	BOLT, M6X 60 PLATED	12							
17	1	23887-180002	PLUG, 18	1							
18	1	128990-49030	PIPE, SEA WATER C	1							
19	1	128990-81150	SPACER, CLUTCH	1							
20	1	26106-080452	BOLT, M8X 45 PLATED	5							
21	1	26216-080452	STUD, M8X 45	3							
22	1	26366-080002	NUT, M8	3							

Fig.4. MOUNTING FOOT

(A)=2YM15
(B)=
(C)=

(D)=
(E)=
(F)=

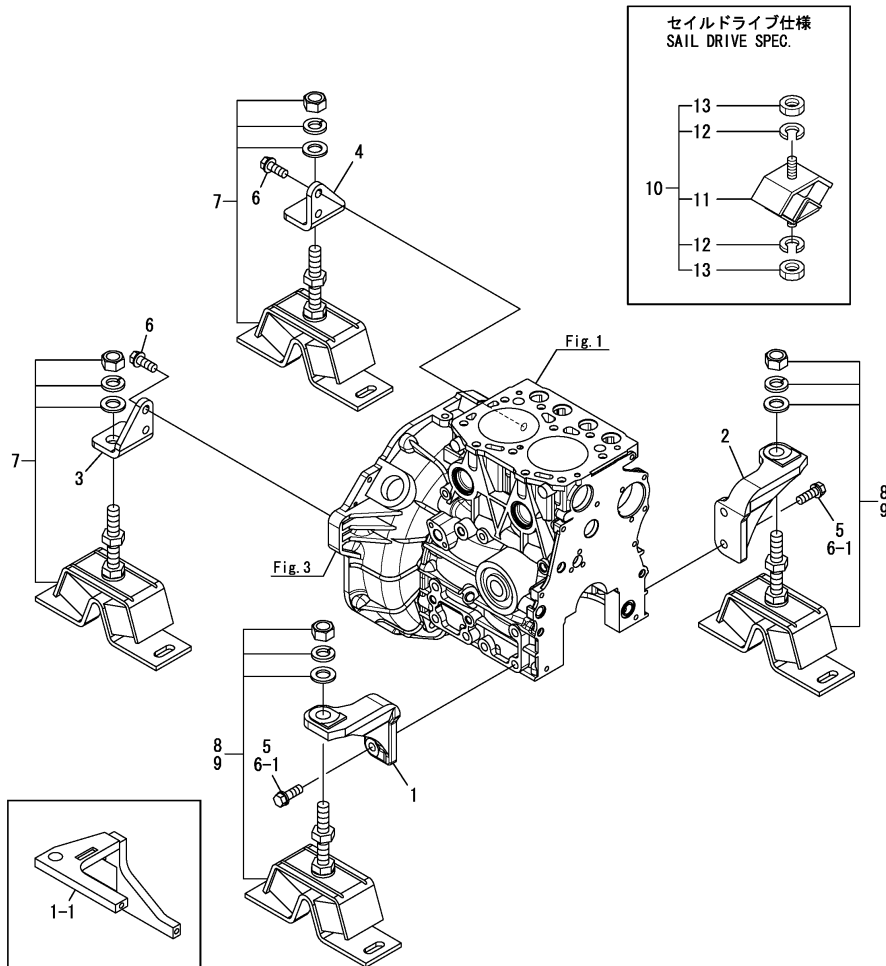

No.	Lev.	Parts No.	Description	Q'ty						I	R
				(A)	(B)	(C)	(D)	(E)	(F)		
1	1	128790-08120	FOOT, MOUNTING A	1							
1-1	1	128790-08150	FOOT, ENGINE FRONT	1							S 2
(A=E/#E6836)											
2	1	128790-08130	FOOT, MOUNTING B	1							
3	1	128377-08120	FOOT, MOUNTING R A	1							
4	1	128377-08130	FOOT, MOUNTING R B	1							
5	1	26013-100302	BOLT, M10X 30	4							Z
(A=E/#E6836)											
6	1	26106-100252	BOLT, M10X 25 PLATED	4							
6-1	1	26106-100252	BOLT, M10X 25 PLATED	8							K
(A=E/#E6836)											
7	1	128377-08340	MOUNT, FLEXIBLE 75	2							
7-1	1	128377-08341	MOUNT, FLEXIBLE 75	2							R
(A=E/#E7173)											
7-2	1	128270-08341	MOUNT, FLEXIBLE 75	2							R
(A=*2020.04)											
8	1	128377-08350	MOUNT, FLEXIBLE 100	2							
8-1	1	128377-08351	MOUNT, FLEXIBLE 100	2							R
(A=E/#E7173)											
8-2	1	124772-08341	MOUNT, FLEXIBLE 100	2							R
(A=*2020.04)											
9	1	128377-08350	MOUNT, FLEXIBLE 100	2							1
9-1	1	128377-08351	MOUNT, FLEXIBLE 100	2							R 1
(A=E/#E7173)											
9-2	1	124772-08341	MOUNT, FLEXIBLE 100	2							R 1
(A=*2020.04)											
10	1	796420-08620	ABSORBER ASSY, SHOCK	1							W
(A=*2014.07.)											
11	2	129795-08340	RUBBER, CUSHION 150	1							W
(A=*2005.11.)											
12	2	22217-120000	WASHER, SPRING 12	2							W
(A=*2005.11.)											
13	2	26716-120002	NUT, M12	2							W
(A=*2005.11.)											

Remarks
(1)Optional : Sail Drive specification.
(2)Fig.41 interchangeable by set.

Fig.5. LABEL

(A)=2YM15
(B)=
(C)=

(D)=
(E)=
(F)=

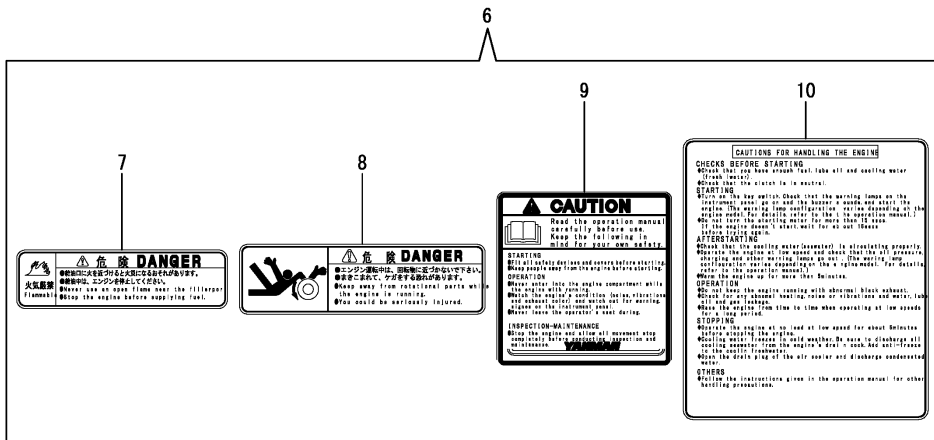
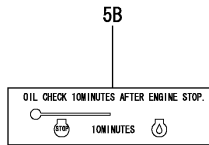
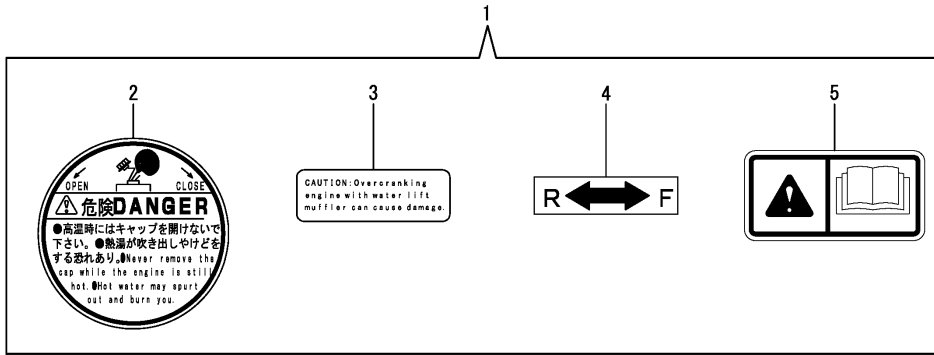

No.	Lev.	Parts No.	Description	Q'ty						I	R
				(A)	(B)	(C)	(D)	(E)	(F)		
1	1	128990-07900	LABEL ASSY, CAUTION	1							W
		(A)=E/#E7170									
2	2	128990-07270	LABEL, PRESSURE CAP	1							
3	2	128377-07150	LABEL, CAUTION	1							
4	2	177088-02430	LABEL	1							W
		(A)=E/#E7170									
5	2	196630-12980	LABEL, CAUTION	1							
5A	1	123682-07852	LABEL, CAUTION	1							
5B	1	128990-34900	LABEL, OIL CHECK	1							W
		(A)=E/#E7170									
5C	1	128377-07350	LABEL, CAUTION	1							Z
		(A)=E/#E7170									
6	1	128296-07190	LABEL, LOOSE PARTS	1							
7	2	128296-07400	LABEL, DANGER	2							
8	2	128296-07420	LABEL, DANGER	1							
9	2	128296-07450	LABEL, CAUTION	1							
10	2	128296-07460	LABEL, OPERATION	1							

Fig.6. CYLINDER HEAD & BONNET

(A)=2YM15

(B)=

(C)=

(D)=

(E)=

(F)=

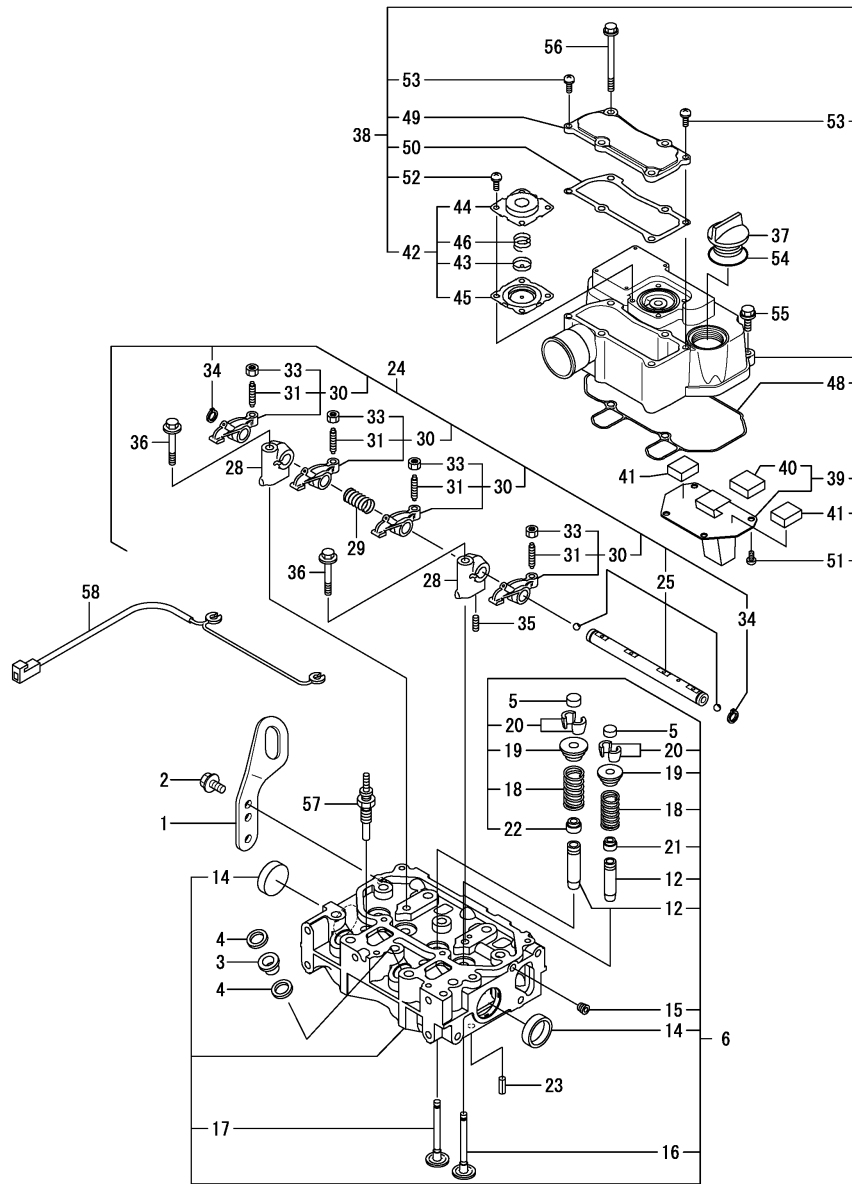

No.	Lev.	Parts No.	Description	Q'ty						I	R
				(A)	(B)	(C)	(D)	(E)	(F)		
1	1	128990-07910	LIFTER	1							
2	1	26106-080142	BOLT, M8X 14 PLATED	2							
3	1	129901-11450	PROTECTOR, NOZZLE	2							
4	1	119600-11460	GASKET, NOZZLE	4							
5	1	105010-11490	CAP, VALVE	4							
6	1	119415-11750	HEAD ASSY, CYLINDER	1							
12	3	119515-11800	GUIDE, VALVE	4							1
14	3	119285-11990	PLUG, 35	2							
15	3	23876-005000	PLUG, R005	1							
16	2	119515-11100	VALVE, INTAKE	2							
16-1	2	119515-11101	VALVE, INTAKE	2							N
(A=*2006.09.)											
17	2	119515-11110	VALVE, EXHAUST	2							
18	2	119717-11131	SPRING, VALVE	4							
19	2	129508-11180	RETAINER, SPRING	4							
20	2	119717-11190	COTTER, VALVE	8							
21	2	119717-11340	SEAL, VALVE STEM	2							
22	2	119717-11350	SEAL, VALVE STEM	2							
23	1	22351-060012	PIN, SPRING 6.0X12	2							
24	1	119415-11200	SUPPORT ASSY, ROCKER	1							
25	2	119415-11240	SHAFT ASSY, ROCKER	1							
28	2	119717-11260	SUPPORT, ROCKER ARM	2							
29	2	119515-11280	SPRING, SHAFT	1							
30	2	119717-11650	ARM ASSY, ROCKER INT	4							
31	3	129150-11230	SCREW, VALVE ADJUST	4							
33	3	129150-11750	NUT, M8XP1.0	4							
34	2	22242-000120	RING, 12	2							
35	2	26979-050162	SCREW, M5X16	1							
36	1	26106-080402	BOLT, M8X 40 PLATED	2							
37	1	124160-01751	CAP, FILLER	1							
38	1	119415-11380	BONNET ASSY, HEAD	1							
39	2	119717-03031	PLATE, BAFFLE	1							
40	3	119717-03070	BAFFLE, BREATHER	1							
41	2	119717-03070	BAFFLE, BREATHER	2							
42	2	119802-03100	DIAPHRAGM ASSY	1							
43	3	119802-03110	PLATE, DIAPHRAGM	1							
44	3	119802-03121	COVER, DIAPHRAGM	1							
45	3	119802-03131	DIAPHRAGM, BREATHER	1							
46	3	119802-03141	SPRING, DIAPHRAGM	1							
48	2	119415-11310	GASKET, BONNET	1							
49	2	119415-11320	COVER, BONNET	1							
50	2	119415-11330	GASKET, BONNET COVER	1							
51	2	22857-500100	SCREW, 5X10	4							
52	2	22857-500100	SCREW, 5X10	4							
53	2	22857-500160	SCREW, 5X16	2							
54	1	24311-000320	O-RING, 1AP32.0	1							
55	1	26106-060202	BOLT, M6X 20 PLATED	2							
56	1	26106-060752	BOLT, M6X 75 PLATED	4							
57	1	119717-77800	PLUG, GLOW	2							
57-1	1	119717-77801	PLUG, GLOW	2							N

(A=*2012.03.)

Remarks
(1) Spare parts.

Fig.6. CYLINDER HEAD & BONNET

(A)=2YM15
(B)=
(C)=

(D)=
(E)=
(F)=

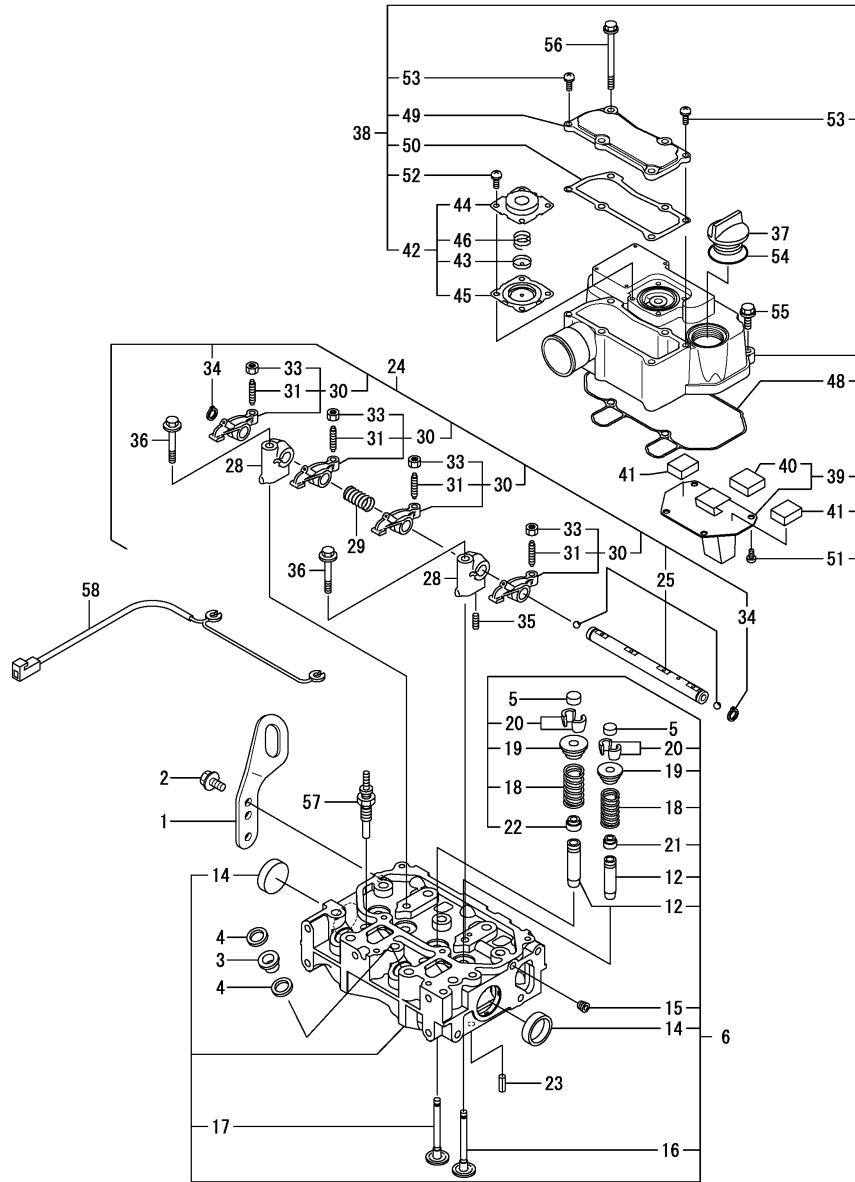

No.	Lev.	Parts No.	Description	Q'ty						I	R
				(A)	(B)	(C)	(D)	(E)	(F)		
58	1	128790-77820	CONNECTOR, GLOW PLUG	1							

Remarks

(1) Spare parts.

Fig.8. MIXING ELBOW

(A)=2YM15
(B)=
(C)=

(D)=
(E)=
(F)=

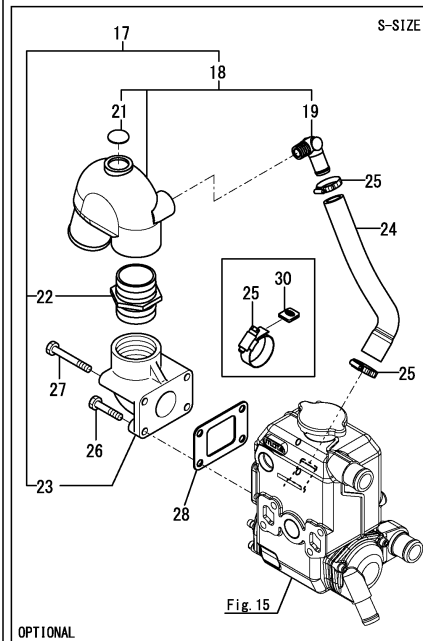
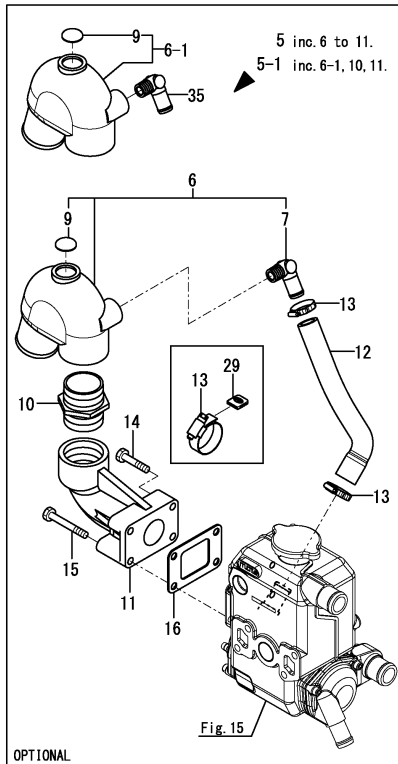
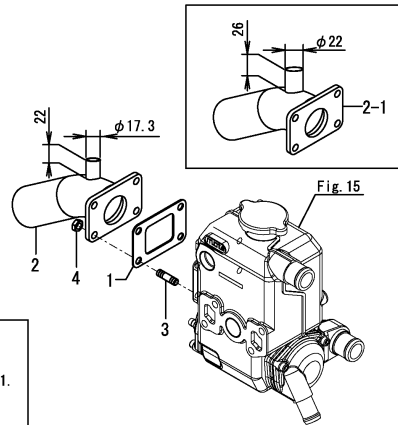
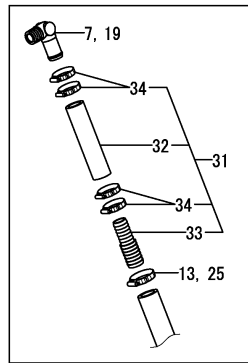

No.	Lev.	Parts No.	Description	Q'ty						I	R
				(A)	(B)	(C)	(D)	(E)	(F)		
1	1	128370-13201	GASKET, ELBOW A	1							
2	1	128397-13530	ELBOW	1							
2-1	1	128890-13530	ELBOW, MIXING	1						S	1
(A=E/#E4990)											
3	1	128170-13600	STUD, M8X31	4							
3-1	1	129670-13600	STUD, M8X20	4							R
(A=E/#E7170)											
4	1	26703-080002	NUT, M8	4							
5	1	128370-13600	ELBOW	1							W
(A=E/#E7170)											
5-1	1	128370-13601	ELBOW ASSY,U-MIXIN R	1							F 3
(A=*2021.02)											
5A	1	128890-13600	ELBOW ASSY,U-MIXING	1							W 2
(A=*2018.10.)											
5A-1	1	128890-13601	ELBOW ASSY,U-MIXIN E	1							F 4
(A=*2021.02)											
6	2	124070-13520	ELBOW ASSY, MIXING	1							
6-1	2	128890-13591	ELBOW ASSY,U-MIXING	1							F 3
(A=*2021.02)											
6A	2	128890-13590	ELBOW ASSY,U-MIXING	1							W 2
(A=*2018.10.)											
6A-1	2	128890-13591	ELBOW ASSY,U-MIXING	1							F 4
(A=*2021.02)											
7	3	124070-13300	ELBOW, PT3/8	1							Z
(A=*2021.02)											
9	3	27233-250000	PLUG, 25	1							
10	2	104214-13580	JOINT, MIXING ELBOW	1							
11	2	128370-13610	ELBOW, EXHAUST PIPE	1							
12	1	128990-49040	PIPE, WATER B	1							
13	1	23000-025000	CLAMP, 25	2							
13-1	1	23000-028000	CLAMP, 28	2							N
(A=*2013.09.)											
14	1	26203-080402	BOLT, M8X 40 PLATED	2							
14-1	1	26203-080452	BOLT, M8X 45 PLATED	2							N
(A=*2018.10.)											
15	1	26203-080602	BOLT, M8X 60 PLATED	2							
15-1	1	26203-080652	BOLT, M8X 65 PLATED	2							N
(A=*2018.10.)											
16	1	128370-13201	GASKET, ELBOW A	1							
17	1	128990-13510	ELBOW ASSY	1							Z
(A=*2021.02)											
18	2	128990-13520	ELBOW ASSY, MIXING	1							Z
(A=*2021.02)											
19	3	124070-13300	ELBOW, PT3/8	1							Z
(A=*2021.02)											
21	3	27233-250000	PLUG, 25	1							Z
(A=*2021.02)											
22	2	104214-13580	JOINT, MIXING ELBOW	1							Z
(A=*2021.02)											
23	2	128990-13610	BEND, EXHAUST	1							Z
(A=*2021.02)											

Remarks

- (1)No.2-1 & Fig.16 No.3-1 interchangeable by set.
- (2)Starter side.
- (3)Interchangeable by simultaneous replacement with No.35.
- (4)Starter side interchangeable by simultaneous replacement with No.35.

Fig.8. MIXING ELBOW

(A)=2YM15

(B)=

(C)=

(D)=

(E)=

(F)=

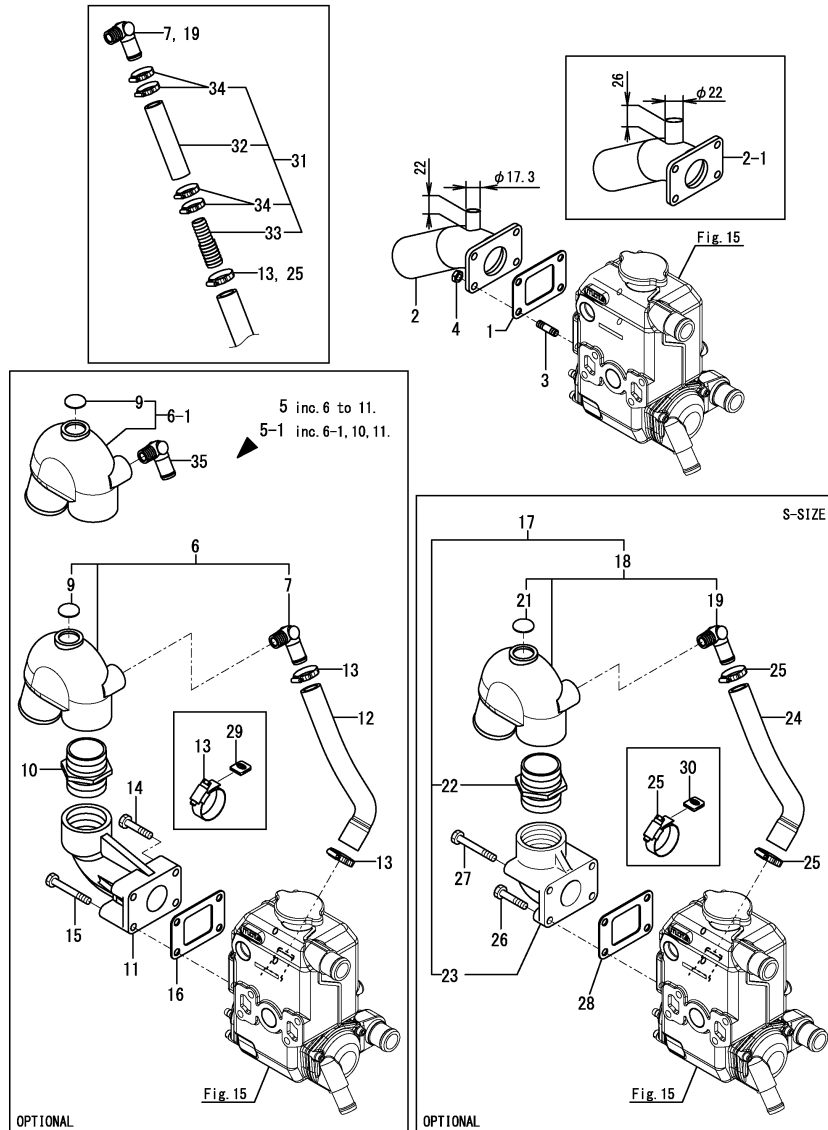

No.	Lev.	Parts No.	Description	Q'ty						I	R
				(A)	(B)	(C)	(D)	(E)	(F)		
24	1	128990-49090 (A=*2021.02)	PIPE, SEA WATER B	1							Z
25	1	23000-025000 (A=*2021.02)	CLAMP, 25	2							Z
26	1	26203-080302 (A=*2021.02)	BOLT, M8X 30 PLATED	2							Z
27	1	26203-080802 (A=*2021.02)	BOLT, M8X 80 PLATED	2							Z
28	1	128370-13201 (A=*2021.02)	GASKET, ELBOW A	1							Z
29	1	129677-49950 (A=E/#E7573)	PROTECTOR,HOSE CLAMP	2							W
30	1	129677-49950 (A=E/#E7573)	PROTECTOR,HOSE CLAMP	2							W
30-1	1	129677-49950 (A=*2021.02)	PROTECTOR,HOSE CLAMP	2							Z
31	1	128990-49120	HOSE KIT,U-MIXING	1							
32	2	128990-49130	HOSE,U-MIXING	1							
33	2	128990-49140	ADAPTER, HOSE 16/19	1							
34	2	23000-028000	CLAMP, 28	4							
35	1	128890-49300 (A=*2021.02)	ELBOW, R3/8X19	1							F

Remarks

- (1)No.2-1 & Fig.16 No.3-1 interchangeable by set.
- (2)Starter side.
- (3)Interchangeable by simultaneous replacement with No.35.
- (4)Starter side interchangeable by simultaneous replacement with No.35.

Fig.9. CAMSHAFT & DRIVING GEAR

(A)=2YM15
(B)=
(C)=

(D)=
(E)=
(F)=

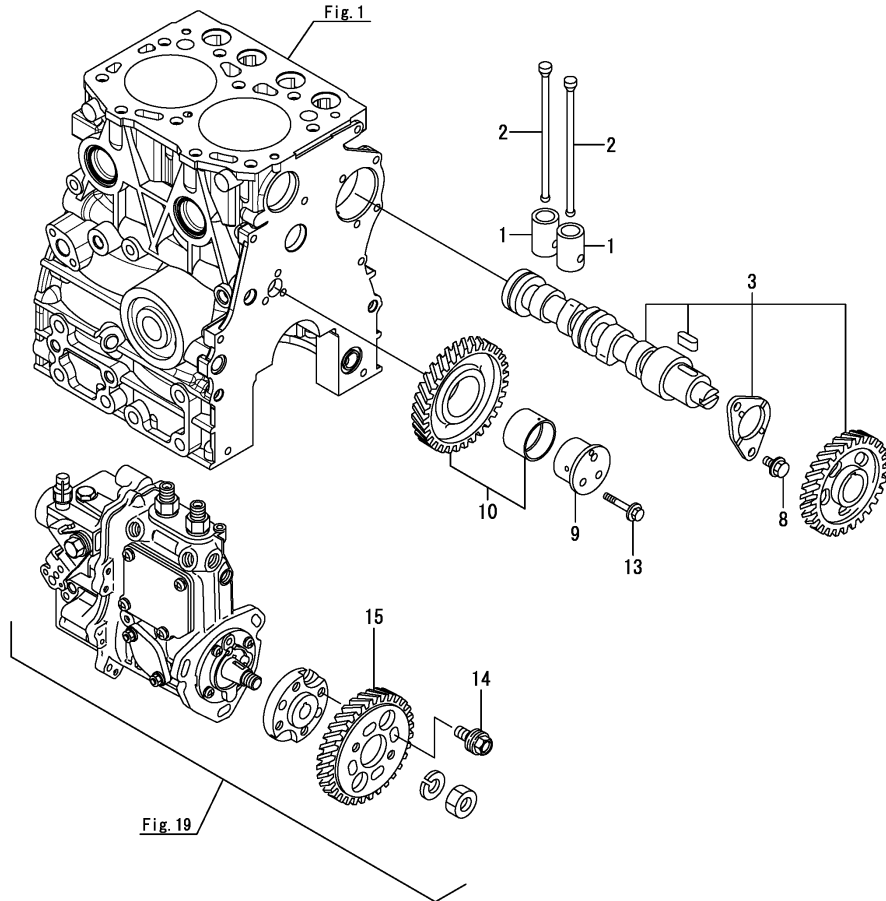

No.	Lev.	Parts No.	Description	Q'ty						I	R
				(A)	(B)	(C)	(D)	(E)	(F)		
1	1	119620-14200	TAPPET	4							
2	1	119515-14400	ROD, PUSH	4							
3	1	119415-14580	CAMSHAFT ASSY	1							
3-1	1	119415-14581	CAMSHAFT ASSY	1							R
		(A=*2006.06.)									
8	1	26106-060122	BOLT, M6X 12 PLATED	2							
9	1	119717-25050	SHAFT, IDLE GEAR	1							
10	1	119717-25100	GEAR ASSY, IDLE	1							
10-1	1	119717-25101	GEAR ASSY, IDLE	1							N
		(A=*2006.06.)									
13	1	26106-060352	BOLT, M6X 35 PLATED	3							
14	1	129150-25301	BOLT, INJECTION PUMP	4							
15	1	119717-25930	GEAR, PUMP	1							

Fig.10. CRANKSHAFT & PISTON

(A)=2YM15

(B)=

(C)=

(D)=

(E)=

(F)=

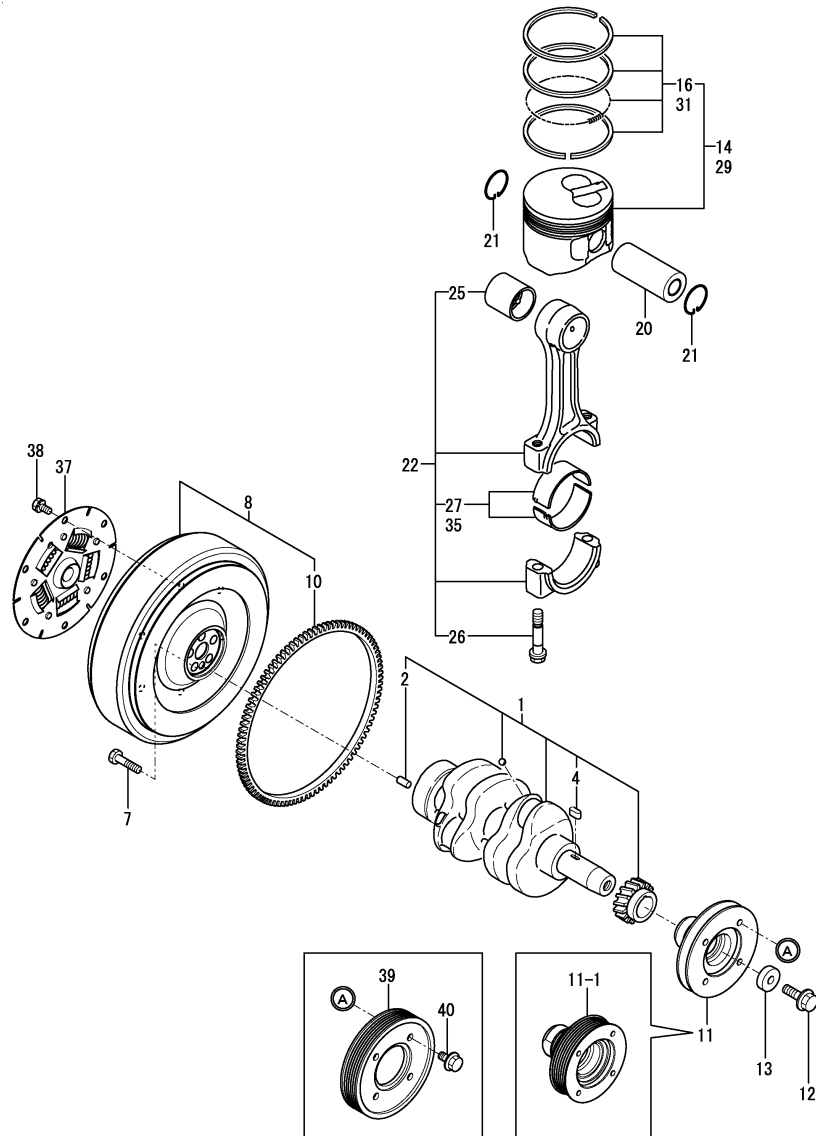

No.	Lev.	Parts No.	Description	Q'ty						I	R
				(A)	(B)	(C)	(D)	(E)	(F)		
1	1	119415-21700	CRANKSHAFT ASSY	1							
2	2	129100-01580	PIN, PARALLEL 8X16	1							
4	2	22512-040120	KEY, 4X 12	1							
7	1	121111-21501	BOLT, FLYWHEEL	5							
8	1	128790-21590	FLYWHEEL ASSY	1							
10	2	124950-21600	GEAR, RING Z=97	1							
11	1	128990-21650	V-PULLEY, CRANKSHAFT	1							
11-1	1	128790-21670 (A=EE08848)	PULLEY,CRANK 100	1						S	5
12	1	119621-21680	BOLT, FLANGE 12X1.25	1							
12-1	1	119621-21681 (A=*2009.07.)	BOLT, FLANGE 12X1.25	1							R
13	1	119620-21941	WASHER, 12	1							
14	1	119515-22080	PISTON ASSY	2							
16	2	119515-22500	RING SET, PISTON	2							
20	1	119515-22300	PIN, PISTON	2							
21	1	22252-000220	RING, 22	4							
22	1	119515-23000	ROD ASSY, CONNECTING	2							
22-1	1	119515-23001 (A=*2018.08.)	ROD ASSY, CONNECTING	2							N
25	2	119717-23910	METAL, PISTON PIN	2							1
26	2	119717-23200	BOLT, CONNECTING ROD	4							
27	2	119515-23600	METAL ASSY,CRANK PIN	2							
27-1	2	119515-23601 (A=*2006.06.)	METAL ASSY,CRANK PIN	2							N
29	1	119515-22900	PISTON ASSY, 0.25 OS	2							2
31	2	119515-22550	RING SET, PISTON .25	2							2
35	1	119515-23610	BEARING ASSY, 0.25	2							3
35-1	1	119515-23611 (A=*2006.06.)	METAL ASSY, PIN .25	2							N 3
37	1	177070-03501	DISK, DAMPER D170	1							
38	1	26013-080142	BOLT, M8X 14	6							
39	1	128990-21670	PULLEY, CRANK 6PK	1							W 4
		(A=E/#E5888)									
39-1	1	128990-21671 (A=E/#E6820)	PULLEY, CRANK 6PK	1							N
39-2	1	128990-21671 (A=EE08848)	PULLEY, CRANK 6PK	1							Z
40	1	26106-080162	BOLT, M8X 16 PLATED	4							W 4
		(A=E/#E5888)									
40-1	1	26106-080162 (A=EE08848)	BOLT, M8X 16 PLATED	4							Z

Remarks

- (1) Spare parts.
- (2) Over-sized (O.S.=0.25) parts.
- (3) Under-sized (U.S.=0.25) parts.
- (4) Valeo generator specification.
- (5) No.11-1 is interchangeable with a set of Fig.14 No.47-2, Fig.37 No.1-1 & Fig.38 No.1-5.

Fig.12. LUB. OIL SYSTEM

(A)=2YM15
(B)=
(C)=

(D)=
(E)=
(F)=

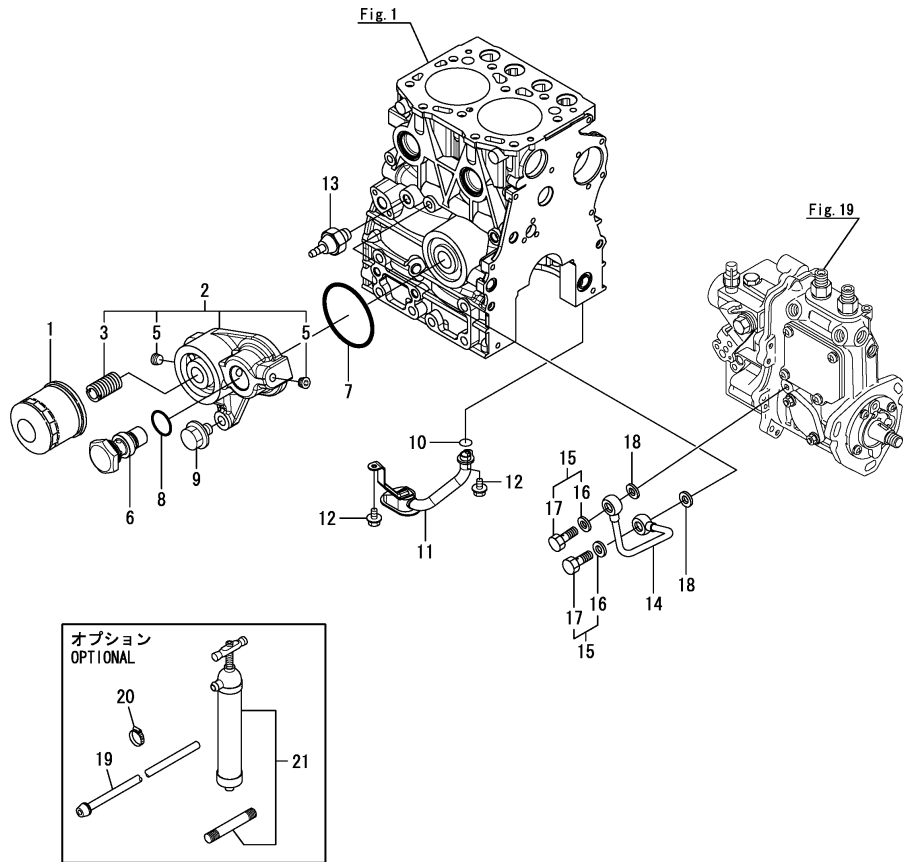

No.	Lev.	Parts No.	Description	Q'ty						I	R
				(A)	(B)	(C)	(D)	(E)	(F)		
1	1	119305-35151	FILTER ASSY, D68XL65	1							1
1-1	1	119305-35170	FILTER ASSY, D68XL65	1							R 2
2	1	128790-35450	BRACKET ASSY, FILTER	1							
3	2	129100-35140	STUD	1							
5	2	23876-010000	PLUG, R01	2							
6	1	128790-35460	BOLT	1							
7	1	24327-000600	O-RING, 4EG60.0	1							
8	1	24357-240230	O-RING, 4E24023	1							
9	1	26106-100302	BOLT, M10X 30 PLATED	1							
10	1	119717-32060	O-RING, P15.0	1							
11	1	128790-35080	PIPE ASSY, OIL INLET	1							
12	1	26106-060102	BOLT, M6X 10 PLATED	2							
13	1	114250-39450	SWITCH, HYDRAULIC	1							
14	1	119415-39210	PIPE, OIL	1							
14-1	1	119415-39211	PIPE, PUMP	1							N
(A=*2005.12.)											
15	1	129005-59830	BOLT ASSY, JOINT M8	2							
16	2	22190-080002	WASHER, SEAL 8	2							
17	2	23857-030000	BOLT, JOINT 3	2							
18	1	22190-080002	WASHER, SEAL 8	2							
19	1	128275-39710	PIPE, OIL	1							Z
(A=E/#E3920)											
20	1	23080-018000	CLAMP, 18	3							Z
(A=E/#E3920)											
21	1	28210-000080	PUMP	1							Z
(A=E/#E3920)											

Remarks

- (1)Non-branded filter(without Yanmar logo).
- (2)Branded filter(with Yanmar logo).

Fig.13. COOLING PUMP(SEA WATER)(TO E/#E6835)

(A)=2YM15

(B)=

(C)=

(D)=

(E)=

(F)=

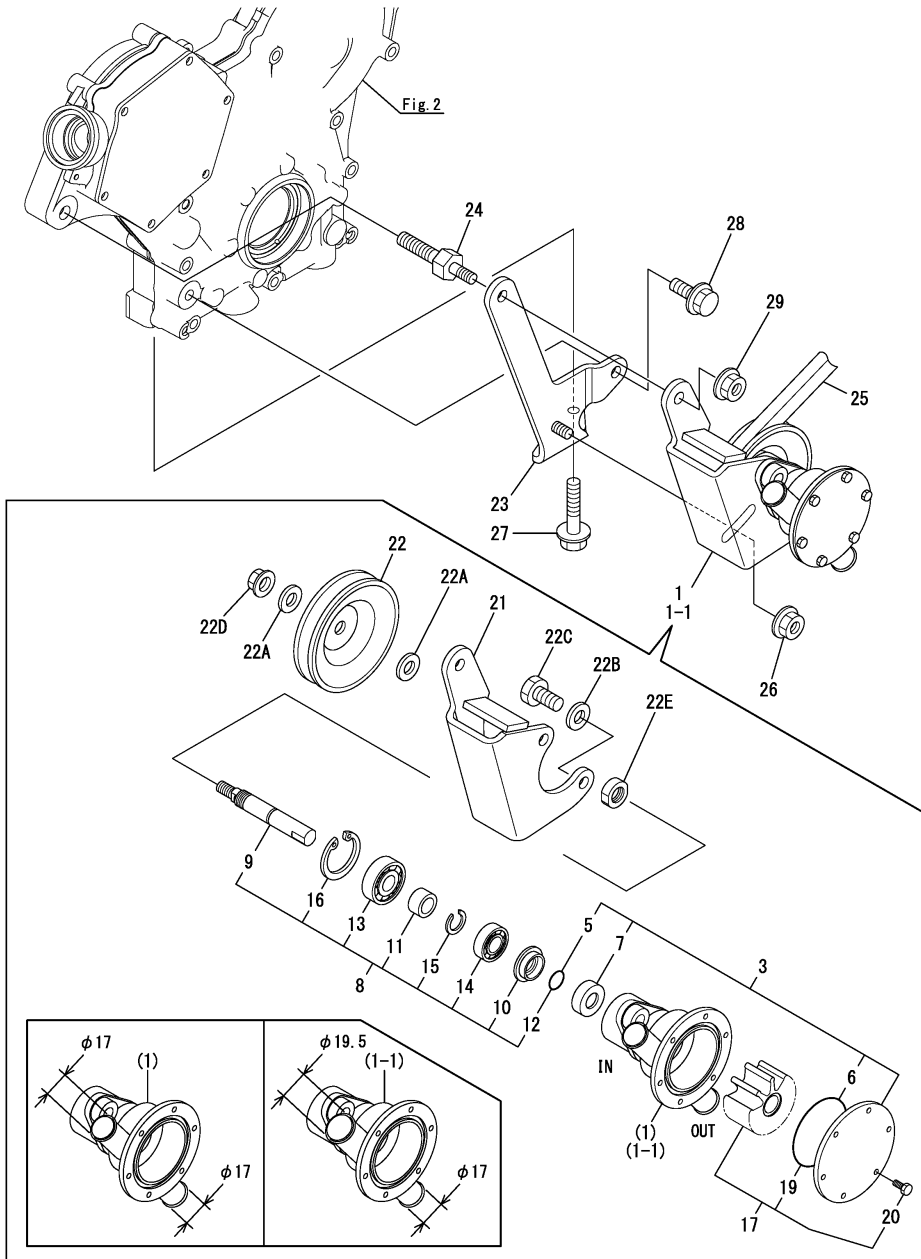

No.	Lev.	Parts No.	Description	Q'ty						I	R
				(A)	(B)	(C)	(D)	(E)	(F)		
1	1	128990-42500	PUMP ASSY, WATER	1							
1-1	1	128990-42510	PUMP ASSY, WATER	1						S	1
(A=E/#E3920)											
1-2	1	128990-42510	PUMP ASSY, WATER	1							Z
(A=E/#E6835)											
3	2	128990-42550	WEAR KIT	1							W
(A=E/#E7525)											
5	3	X02173432	O-RING	1							
6	3	X02173476	O-RING	1							
7	3	X02233010	SEAL, LIP	1							
8	2	128990-42560	SHAFT KIT	1							W
(A=E/#E7525)											
9	3	X0146541	SHAFT, WATER PUMP	1							
10	3	X0145050	PLATE	1							
11	3	X0146542	SPACER	1							
12	3	X02173432	O-RING	1							
13	3	X03431760	BEARING, BALL	1							
14	3	X03431748	BEARING, BALL	1							
15	3	X00370012	RING, RETAINING	1							
16	3	X00371732	RING, RETAINING	1							
17	2	128990-42570	IMPELLER KIT	1							W
(A=E/#E7525)											
19	3	X02173476	O-RING	1							
20	3	128990-42520	SCREW	6							
21	2	128990-42151	BRACKET, PUMP A	1							
22	2	124070-42400	V-PULLEY, PUMP	1							
22A	2	X014678901	WASHER	2							
22B	2	X00353309	WASHER	2							
22C	2	X00141916	SCREW	2							
22D	2	X00190050	NUT, LOCK	1							
22E	2	X00183200	NUT	1							
23	1	128990-42160	BRACKET, PUMP B	1							
24	1	128990-42170	BOLT, SPACER	1							
25	1	104511-78780	V-BELT, M/19	1							
26	1	26366-080002	NUT, M8	1							
27	1	26106-060302	BOLT, M6X 30 PLATED	1							
28	1	26106-080202	BOLT, M8X 20 PLATED	1							
29	1	26366-080002	NUT, M8	1							

Remarks

(1)Interchangeable by simultaneous replacement with loarrangements Pump entrance hose(57mm-68mm).

Fig.41. (13A)COOLING PUMP(SEA WATER)(FROM E/#E6836)

(A)=2YM15
(B)=
(C)=

(D)=
(E)=
(F)=

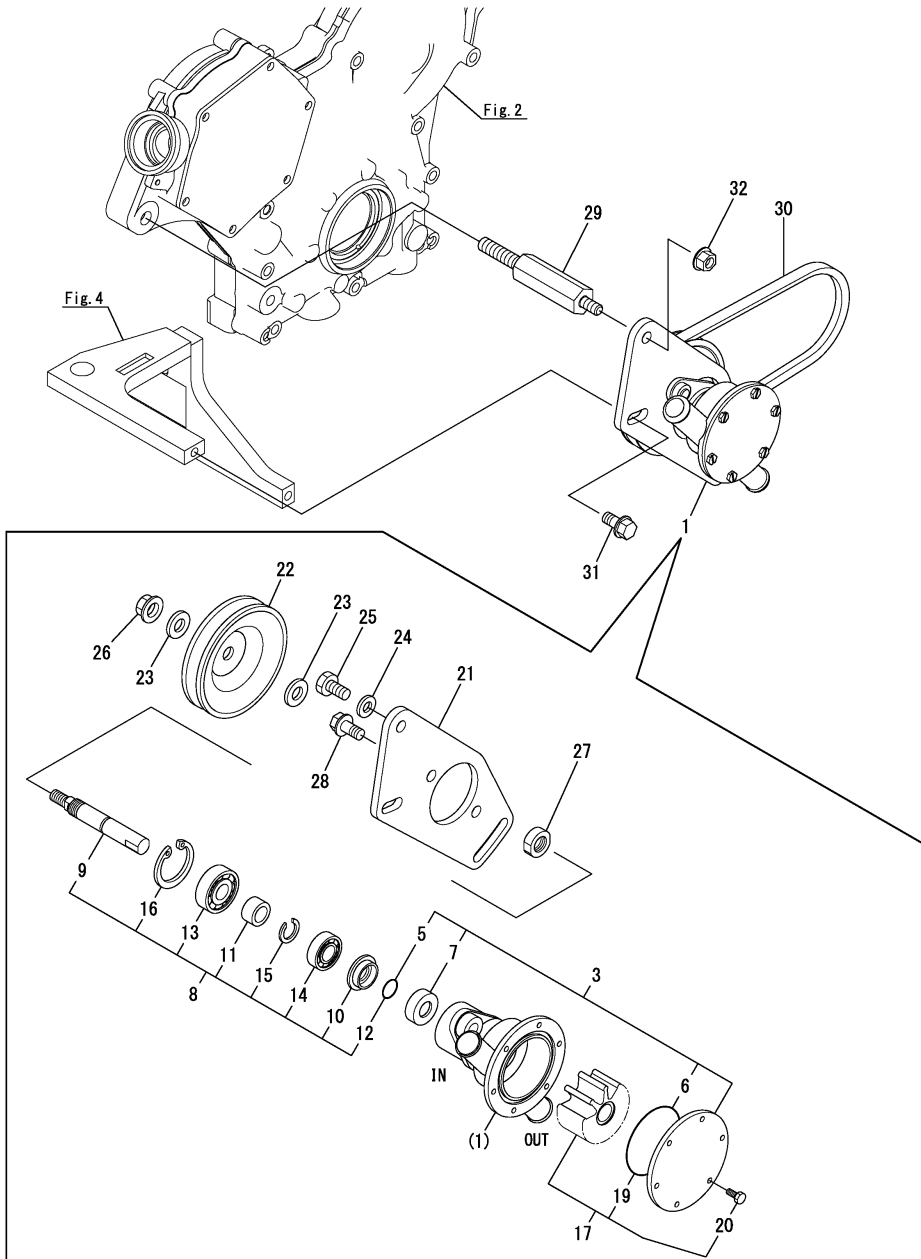

No.	Lev.	Parts No.	Description	Q'ty						I	R
				(A)	(B)	(C)	(D)	(E)	(F)		
1	1	128995-42500 (A=E/#E6836)	PUMP ASSY, WATER	1							W
3	2	128990-42550	WEAR KIT	1							W
5	3	X02173432 (A=E/#E7525)	O-RING	1							
6	3	X02173476	O-RING	1							
7	3	X02233010	SEAL, LIP	1							
8	2	128990-42560 (A=E/#E7525)	SHAFT KIT	1							W
9	3	X0146541	SHAFT, WATER PUMP	1							
10	3	X0145050	PLATE	1							
11	3	X0146542	SPACER	1							
12	3	X02173432	O-RING	1							
13	3	X03431760	BEARING, BALL	1							
14	3	X03431748	BEARING, BALL	1							
15	3	X00370012	RING, RETAINING	1							
16	3	X00371732	RING, RETAINING	1							
17	2	128990-42570	IMPELLER KIT	1							W
19	3	X02173476 (A=E/#E7525)	O-RING	1							
20	3	128990-42520	SCREW	6							
21	2	128995-42150	BRACKET, PUMP	1							
22	2	124070-42400	V-PULLEY, PUMP	1							
23	2	X014678901	WASHER	2							
24	2	X00353309	WASHER	2							
25	2	X00141916	SCREW	2							
26	2	X00190050	NUT, LOCK	1							
27	2	X00183200	NUT	1							
28	2	26106-080162	BOLT, M8X 16 PLATED	2							
29	1	128995-42170	BOLT, PUMP SPACER	1							
30	1	25111-002000	V-BELT	1							
30-1	1	128990-77350 (A=E/#E8240)	V-BELT, M/20	1							R
31	1	26106-080162	BOLT, M8X 16 PLATED	1							
32	1	26366-080002	NUT, M8	1							

Remarks
* Fig.4 No. 1-1 interchangeable by set.

Fig.14. COOLING PUMP(FRESH WATER)

(A)=2YM15
(B)=
(C)=

(D)=
(E)=
(F)=

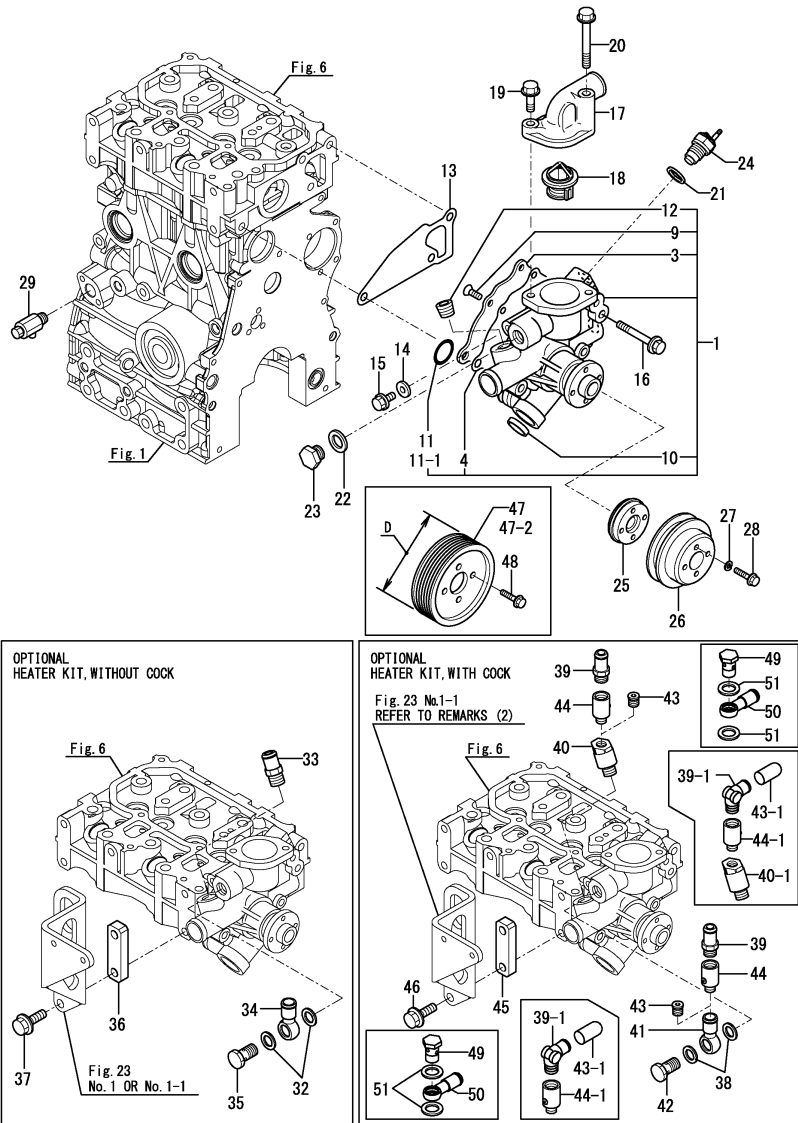

No.	Lev.	Parts No.	Description	Q'ty						I	R
				(A)	(B)	(C)	(D)	(E)	(F)		
1	1	119540-42000	PUMP ASSY, WATER	1							
1-1	1	119C10-42000	PUMP ASSY, WATER	1							N
(A=*2012.02.)											
3	2	119515-42041	COVER, WATER PUMP	1							
4	2	119717-42031	GASKET, WATER PUMP	1							
9	2	26577-060122	SCREW, M6X12	4							
10	2	27241-250000	PLUG, 25	1							
11	2	119717-42320	O-RING, P26	1							
11-1	2	119C10-42320	O-RING, 2028	1							S
(A=*2012.02.)											
12	2	129916-49740	PLUG, R3/8	1							
13	1	119515-42020	GASKET, WATER PUMP	1							
14	1	23414-080000	GASKET, 8X1.0	1							
15	1	26106-080122	BOLT, M8X 12 PLATED	1							
16	1	26106-080502	BOLT, M8X 50 PLATED	3							
17	1	124101-49530	COVER, THERMOSTAT	1							
18	1	128990-49800	THERMOSTAT, 71C	1							
19	1	26106-080252	BOLT, M8X 25 PLATED	1							
20	1	26106-080652	BOLT, M8X 65 PLATED	1							
21	1	124465-44950	GASKET, 16	1							
22	1	124465-44950	GASKET, 16	1							
23	1	121450-42450	PLUG, M16	1							
24	1	46150-503100	SWITCH, THERMO 95C	1							
24-1	1	128990-44500	SWITCH, TEMPERATURE	1							N
(A=E/#E1415)											
25	1	128990-42260	SPACER, PUMP	1							Z
(A=E/#E5887)											
26	1	119740-42350	V-PULLEY, PUMP D=90	1							Z
(A=E/#E5887)											
27	1	22217-060000	WASHER, SPRING 6	4							Z
(A=*2008.03.)											
28	1	26106-060282	BOLT, M6X 28 PLATED	4							
28-1	1	26106-060252	BOLT, M6X 25 PLATED	4							R
(A=*2008.03.)											
28-2	1	26106-060252	BOLT, M6X 25 PLATED	4							Z
(A=E/#E5887)											
29	1	119620-49290	COCK ASSY, 1/4	1							
32	1	124465-44950	GASKET, 16	2							Z 1
(A=E/#E3920)											
33	1	128990-49320	JOINT, 3/8	1							Z 1
(A=E/#E3920)											
34	1	128990-49330	JOINT, WATER RETURN	1							Z 1
(A=E/#E3920)											
35	1	23854-100000	BOLT, JOINT 10	1							Z 1
(A=E/#E3920)											
36	1	128890-55020	SPACER, BRACKET	1							W 1
(A=E/#E7170)											
36-1	1	128890-55020	SPACER, BRACKET	1							Z
(A=E/#E3920)											
37	1	26106-080252	BOLT, M8X 25 PLATED	2							W 1
(A=E/#E7170)											

Remarks

- (1)Heater kit, without cook assy.
- (2)Heater kit, with cook assy.
- To avoid the interference between the joint and lifting hook in use of Fig.23 No.1, please exchange for No.1-1.
- (3)Valeo generator specifications.
- (4)Pully diameter D=No.47-1 : 90mm, No.47-2 : 75mm.
- No.47-2 is interchangeable with a set of Fig.10 No.11-1, Fig.37 No.1-1 & Fig.38 No.1-5.

Fig.14. COOLING PUMP(FRESH WATER)

(A)=2YM15
(B)=
(C)=

(D)=
(E)=
(F)=

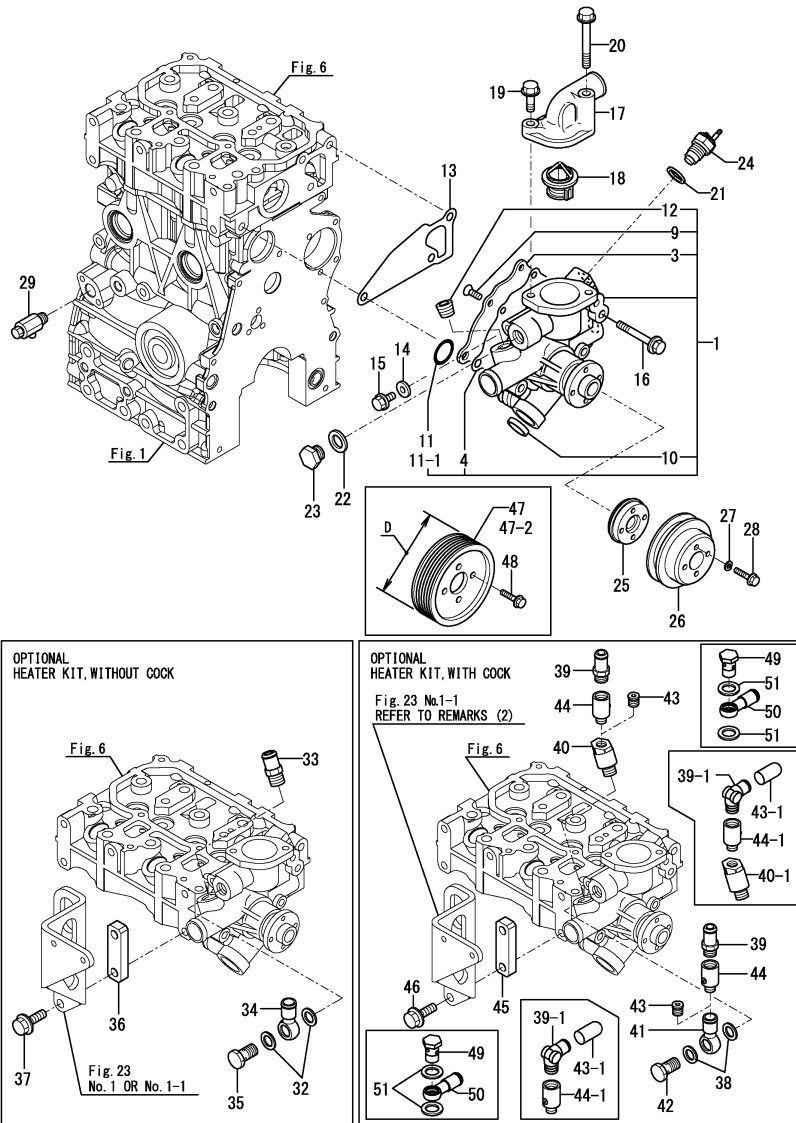

Remarks

- (1) Heater kit, without cook assy.
- (2) Heater kit, with cook assy.
- To avoid the interference between the joint and lifting hook in use of Fig.23 No.1, please exchange for No.1-1.
- (3) Valeo generator specifications.
- (4) Pulley diameter D=No.47-1 : 90mm, No.47-2 : 75mm.
- No.47-2 is interchangeable with a set of Fig.10 No.11-1, Fig.37 No.1-1 & Fig.38 No.1-5.

No.	Lev.	Parts No.	Description	Q'ty						I	R
				(A)	(B)	(C)	(D)	(E)	(F)		
37-1	1	26106-080252 (A=E/#E3920)	BOLT, M8X 25 PLATED	2							Z
38	1	124465-44950	GASKET, 16	2							W 2
39	1	128990-49320 (A=E/#E7170)	JOINT, 3/8	2							W 2
39-1	1	129051-49310 (A=E/#E7754)	ELBOW, PT3/8	2							N
39-2	1	129051-49310 (A=E08176)	ELBOW, PT3/8	2							Z
39-3	1	129051-49310 (A=*2020.02.)	ELBOW, PT3/8	2							W
40	1	128990-49350 (A=E/#E7170)	JOINT, 3/8X1/4	1							W 2
40-1	1	128990-49351 (A=E/#E7754)	JOINT,3/8X1/4 RETURN	1							N
41	1	128990-49360 (A=E/#E7170)	JOINT, OUTLET RP1/4	1							W 2
42	1	128990-49370 (A=E/#E7170)	BOLT, PIPE JOINT	1							W 2
43	1	128990-49380 (A=E/#E7170)	PLUG, R1/4	2							W 2
43-1	1	128990-49400 (A=E/#E7170)	CAP, WATER	2							N
44	1	128990-49390 (A=E/#E7170)	COCK ASSY,R1/4XRP3/8	2							W 2
44-1	1	128990-49391 (A=E/#E7754)	COCK ASSY,R1/4XG3/8	2							R
44-2	1	128990-49392 (A=*2020.02.)	COCK ASSY,R1/4XG3/8	2							S
45	1	128890-55020 (A=E/#E7170)	SPACER, BRACKET	1							W 2
46	1	26106-080252 (A=E/#E7170)	BOLT, M8X 25 PLATED	2							W 2
47	1	128990-42350 (A=E/#E5887)	PULLEY, PUMP 6PK	1							W 3
47-1	1	128990-42351 (A=E/#E6820)	PULLEY, PUMP 6PK	1							N
47-2	1	128790-42350 (A=EE08848)	PULLEY,CW PUMP 75	1							S 4
48	1	26106-060122 (A=E/#E5887)	BOLT, M6X 12 PLATED	4							W 3
49	1	128990-49331 (A=E08176)	JOINT,HOT WATER	2							W
49-1	1	128990-49331 (A=*2020.02.)	JOINT,HOT WATER	2							Z
50	1	128990-49340 (A=E08176)	BOLT,PIPE JOINT G3/8	2							W
50-1	1	128990-49340 (A=*2020.02.)	BOLT,PIPE JOINT G3/8	2							Z
51	1	23414-170000	GASKET, 17X1.0	4							W

Fig.14. COOLING PUMP(FRESH WATER)

(A)=2YM15
(B)=
(C)=

(D)=
(E)=
(F)=

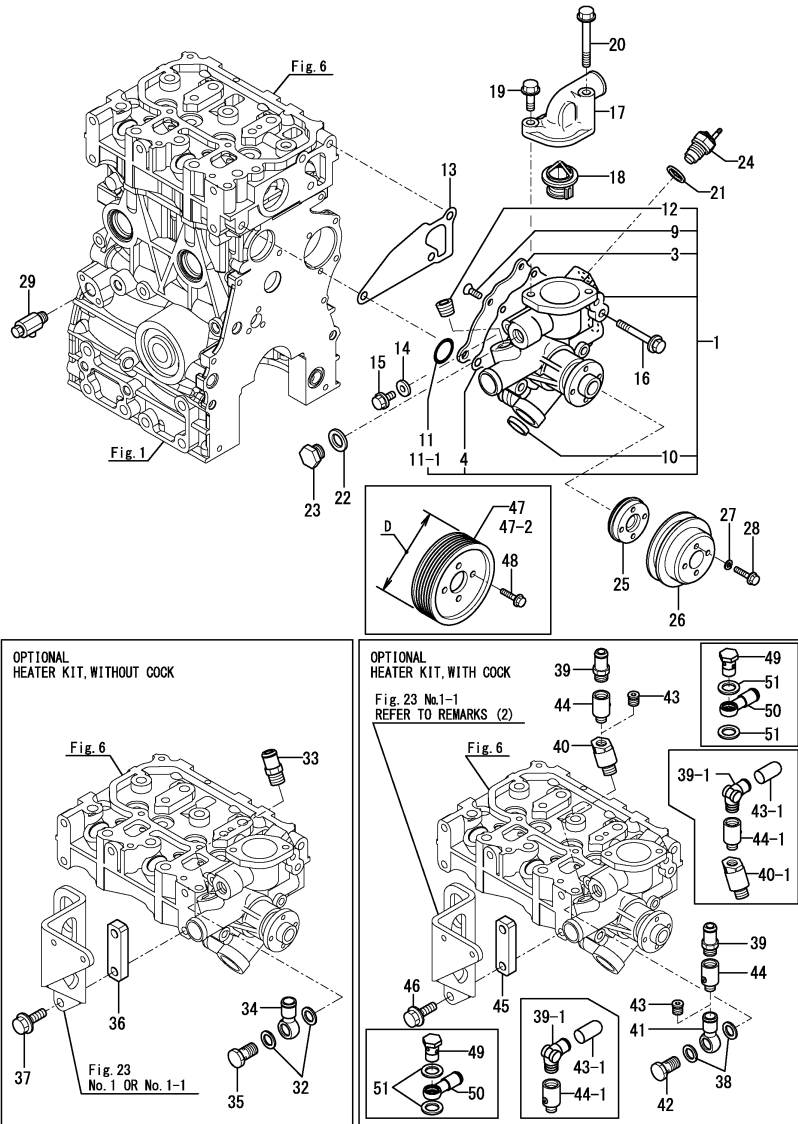

No.	Lev.	Parts No.	Description	Q'ty						I	R
				(A)	(B)	(C)	(D)	(E)	(F)		
51-1	1	23414-170000	GASKET, 17X1.0	4						Z	
		(A=E08176)									
		(A=*2020.02.)									

Remarks

- (1) Heater kit, without cook assy.
- (2) Heater kit, with cook assy.
- To avoid the interference between the joint and lifting hook in use of Fig.23 No.1, please exchange for No.1-1.
- (3) Valeo generator specifications.
- (4) Pully diameter D=No.47-1 : 90mm, No.47-2 : 75mm.
- No.47-2 is interchangeable with a set of Fig.10 No.11-1, Fig.37 No.1-1 & Fig.38 No.1-5.

Fig.15. COOLER(FRESH WATER)

(A)=2YM15
(B)=
(C)=

(D)=
(E)=
(F)=

2 inc. (2)~19

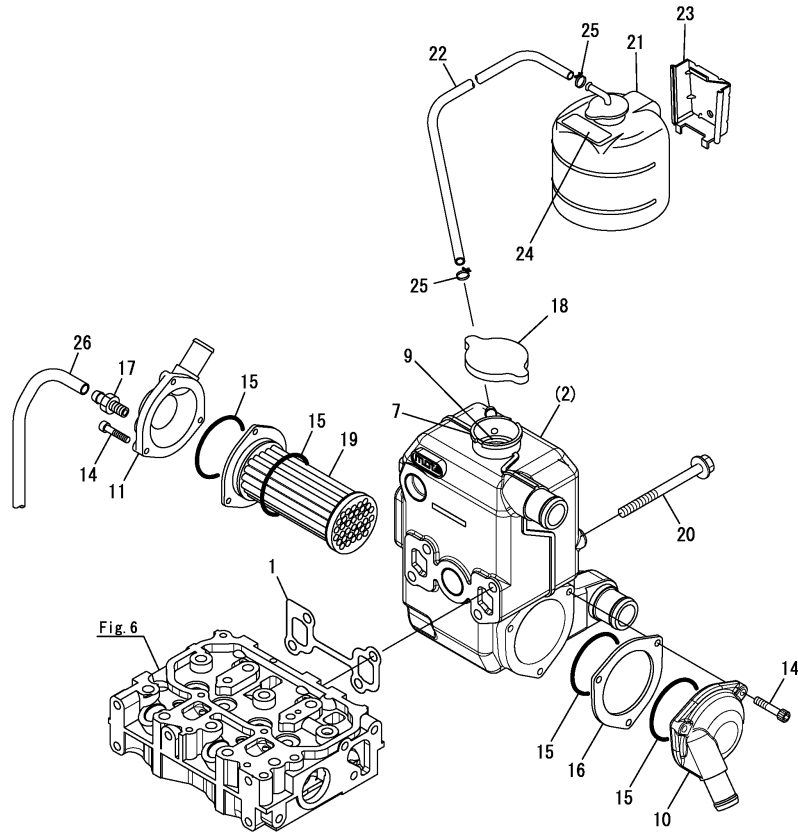

No.	Lev.	Parts No.	Description	Q'ty						I	R
				(A)	(B)	(C)	(D)	(E)	(F)		
1	1	119415-13110	GASKET, MANIFOLD	1							
2	1	128790-44900	COOLER ASSY, WATER	1							
7	3	129673-44110	NECK, FILLER	1							
9	3	129673-44150	TUBE, D28.5X1.5 LG6	1							
10	2	128990-44070	BONNET, INLET	1							
10-1	2	128990-44071	BONNET, INLET	1						S	1
(A=*2005.08.)											
11	2	128990-44080	BONNET ASSY, OUT	1							
11-1	2	128990-44081	BONNET ASSY, OUT	1						S	1
(A=*2005.08.)											
14	2	128990-44090	SCREW, M6X30	6							
15	2	128990-44100	O-RING, D65.6X3.53	4							
16	2	128990-44110	SPACER	1							
17	2	128990-44120	PLUG, DRAIN	1							
18	2	129673-44130	CAP	1							
18-1	2	129673-44131	CAP, FILLER	1							N
(A=*2005.08.)											
19	2	128790-44400	ELEMENT, FRESH WATER	1							
19-1	2	128990-44401	ELEMENT, FRESH WATER	1						S	1
(A=*2005.08.)											
20	1	26106-081152	BOLT, M8X115 PLATED	4							
21	1	128397-44500	TANK ASSY, SUB	1							
22	1	129270-44500	PIPE, OVERFLOW	1							
22-1	1	129270-44501	PIPE, OVERFLOW	1							N
(A=E/#E7170)											
23	1	128397-44510	BRACKET, SUB TANK	1							
24	1	129670-44570	LABEL, SUB TANK	1							
25	1	23010-013000	CLAMP 13	2							
26	1	23061-070300	PIPE, 7X 300	1							W
(A=E/#E7170)											

Remarks

(1)No.10-1, 11-1 & 19-1 interchangeable by set.

Fig.16. COOLING PIPE(SEA WATER)

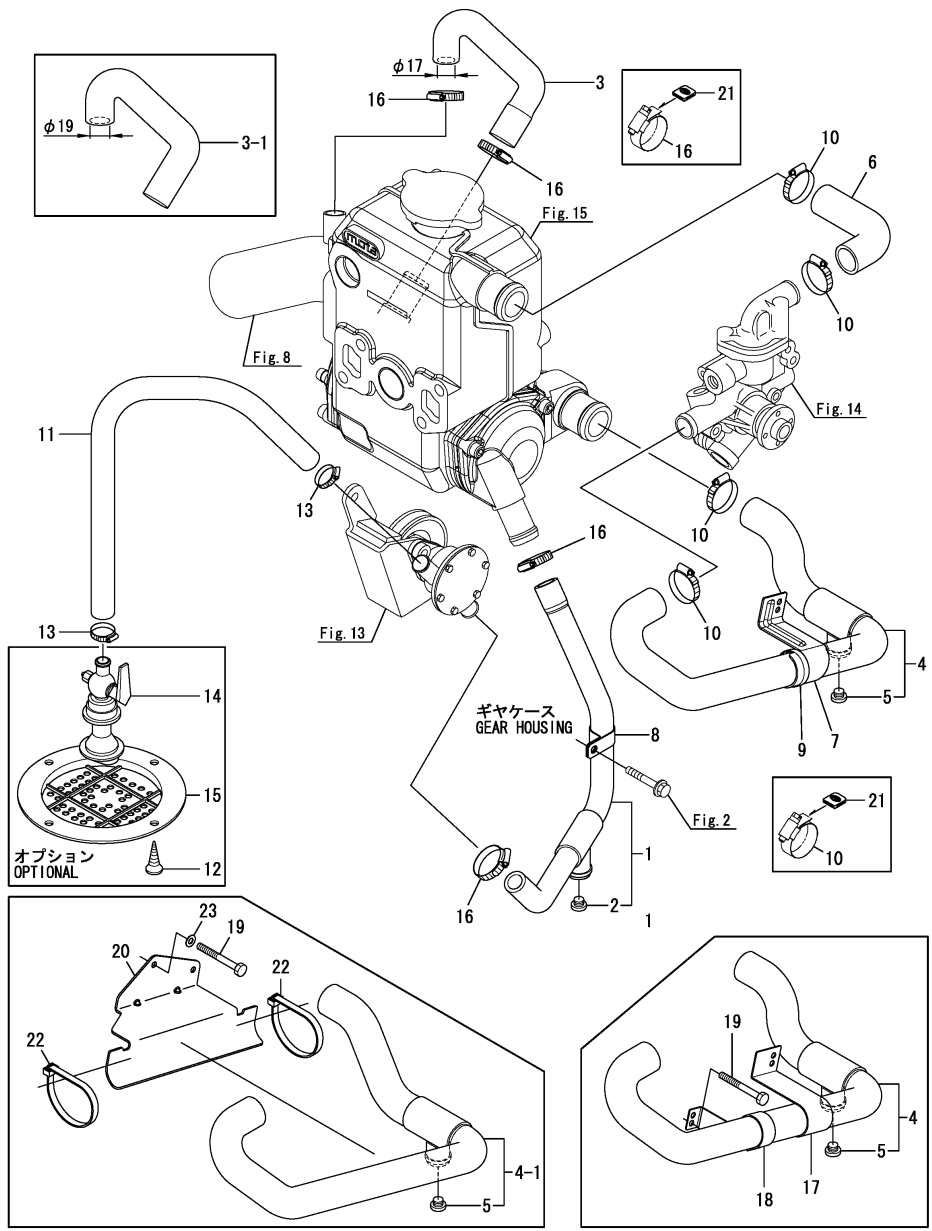

(A)=2YM15

(B)=

(C)=

(D)=

(E)=

(F)=

No.	Lev.	Parts No.	Description	Q'ty						I	R
				(A)	(B)	(C)	(D)	(E)	(F)		
1	1	128990-49010	PIPE, SEA WATER A	1							
1-1	1	128990-49011	PIPE, SEA WATER A	1							R
(A=E/#E6624)											
2	2	128990-49110	PLUG ASSY, G1/8	1							
3	1	128990-49020	PIPE, SEA WATER B	1							
3-1	1	128990-49021	PIPE, SEA WATER B	1							S 1
(A=E/#E4990)											
4	1	128790-49050	PIPE, FRESH WATER A	1							
4-1	1	128790-49051	HOSE ASSY, CFW	1							N
(A=E/#E6521)											
5	2	128990-49110	PLUG ASSY, G1/8	1							
6	1	128990-49060	PIPE, FRESH WATER B	1							
7	1	128990-49150	RETAINER, PIPE	1							Z
(A=E/#E5887)											
8	1	121575-49310	RETAINER, PIPE	1							
9	1	194250-51660	BAND, NYLON 250	1							
9-1	1	29622-250001	BAND, RF250	1							R
(A=*2012.05.)											
9-2	1	29622-250001	BAND, RF250	1							Z
(A=E/#E5887)											
10	1	23000-041000	CLAMP, 41	4							
10-1	1	129670-49500	CLIP, HOSE 38	4							R
(A=E/#E5888)											
11	1	124223-49050	PIPE, SEA WATER A	1							
12	1	22724-800380	SCREW, 8.0X38	4							
13	1	23000-025000	CLAMP, 25	2							
14	1	43662-015020	COCK ASSY, KINGSTON	1							
14-1	1	43662-015021	COCK, KINGSTON 15A	1							N
(A=*2007.03.)											
15	1	43666-020951	COVER, STRAINER	1							
16	1	23000-028000	CLAMP, 28	4							
17	1	128990-49161	RETAINER, HOSE	1							W 2
(A=E/#E5888)											
17-1	1	128990-49161	RETAINER, HOSE	1							Z
(A=E/#E6521)											
18	1	128990-49170	RETAINER, HOSE	1							W 2
(A=E/#E5888)											
18-1	1	128990-49170	RETAINER, HOSE	1							Z
(A=E/#E6521)											
19	1	26116-060652	BOLT, M6X 65 PLATED	1							W 2
(A=E/#E5888)											
20	1	128990-49190	RETAINER,CFW HOSE	1							W
(A=E/#E6521)											
21	1	129677-49950	PROTECTOR,HOSE CLAMP	6							W
(A=E/#E7573)											
22	1	128990-59890	BAND, 200	2							W
(A=E/#E6521)											
23	1	22137-060000	WASHER, 6	1							W
(A=E/#E6521)											

Remarks

(1)No.3-1 & Fig.8 No.2-1 interchangeable by set.

(2)Valeo generator specification.

Fig.17. BILGE PUMP(STANDARD)(OPTIONAL)(TO APR. 2004)

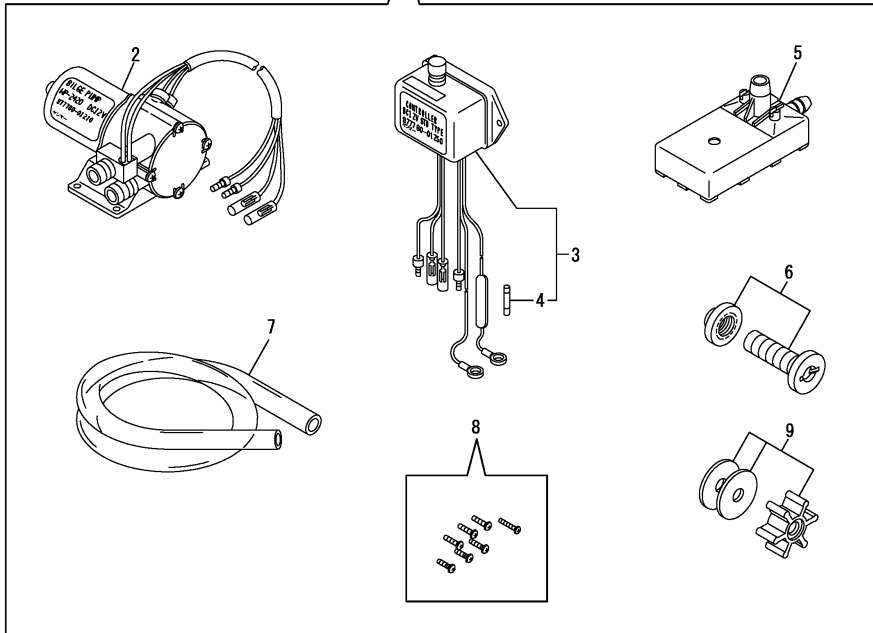
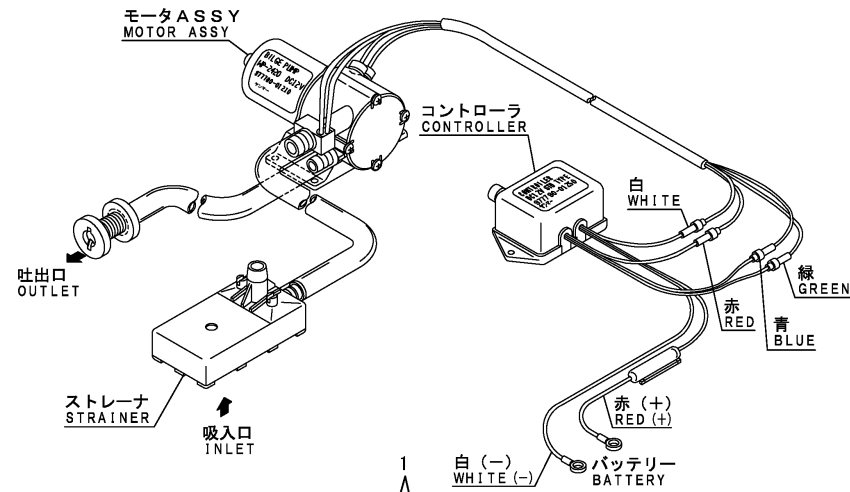

(A)=2YM15
(B)=
(C)=

(D)=
(E)=
(F)=

No.	Lev.	Parts No.	Description	Q'ty						I	R
				(A)	(B)	(C)	(D)	(E)	(F)		
1	1	977780-01210	PUMP(12V),BILGE	1							1
2	2	977780-01230	MOTOR ASSY(BILG PUMP)	1							
3	2	977780-01250	CONTROLLER	1							
4	3	X8636008003	FUSE, 8A	1							
5	2	X179100021X	STRAINER	1							
6	2	X179100100X	PIPE ASSY	1							
7	2	X0044021509	HOSE, A	1							
8	2	X199903800X	SCREW KIT	1							
9	2	977780-03000	IMPELLER KIT	1							

Remarks

(1)Inner parts are shown in Fig.40(18A).

Fig.18. BILGE PUMP(DELUXE)(OPTIONAL)(TO APR. 2004)

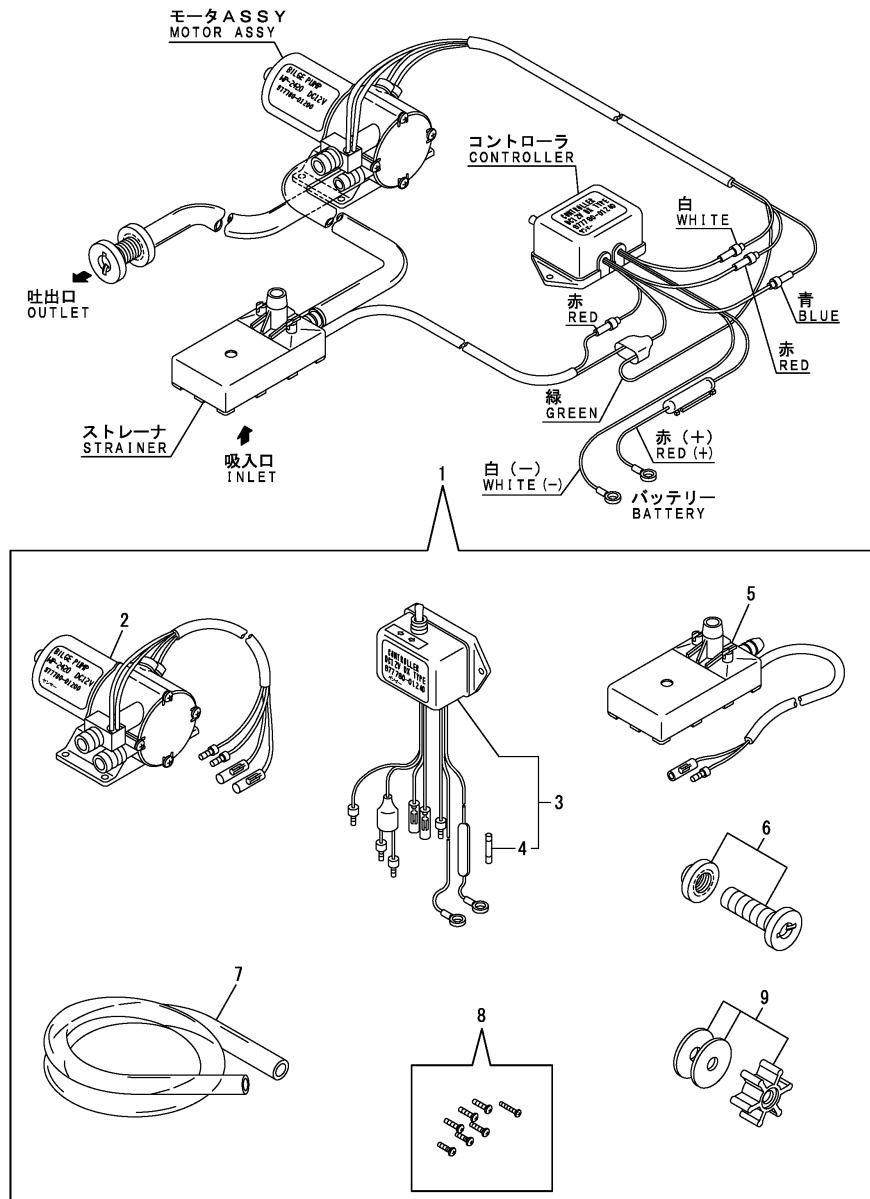

(A)=2YM15
(B)=
(C)=

(D)=
(E)=
(F)=

No.	Lev.	Parts No.	Description	Q'ty						I	R
				(A)	(B)	(C)	(D)	(E)	(F)		
1	1	977780-01200	PUMP(12V),BILGE	1							1
2	2	977780-01230	MOTOR ASSY(BILG PUMP)	1							
3	2	977780-01240	CONTROLLER	1							
4	3	X8636008003	FUSE, 8A	1							
5	2	X179100011X	STRAINER	1							
6	2	X179100100X	PIPE ASSY	1							
7	2	X0044021509	HOSE, A	1							
8	2	X199903800X	SCREW KIT	1							
9	2	977780-03000	IMPELLER KIT	1							

Remarks

(1)Inner parts are shown in Fig.40(18A).

Fig.40. (18A)BILGE PUMP(OPTIONAL)(FROM MAR. 2004)

(A)=2YM15
(B)=
(C)=

(D)=
(E)=
(F)=

No.	Lev.	Parts No.	Description	Q'ty						I	R
				(A)	(B)	(C)	(D)	(E)	(F)		
1	1	977780-01211	PUMP ASSY, BILGE	1							
2	2	X0318101004	MOTOR ASSY, BILGE	1							
3	2	X158606410X	SWITH	1							
4	3	X8636015001	FUSE, 15A 12V	1							
5	2	X179100022X	STRAINER	1							
6	2	X179100100X	PIPE ASSY	1							
7	2	X0044021509	HOSE, A	1							
8	2	X199906101X	SCREW SET	1							
9	2	977780-03000	IMPELLER KIT	1							

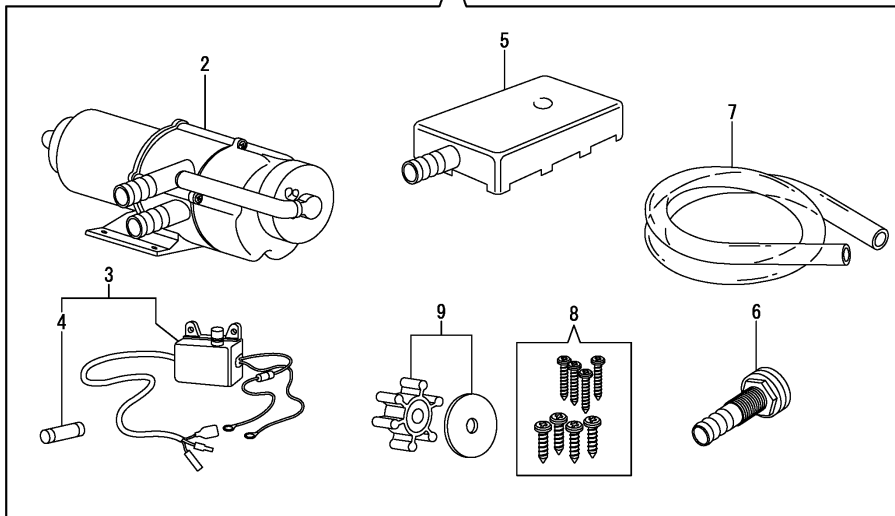
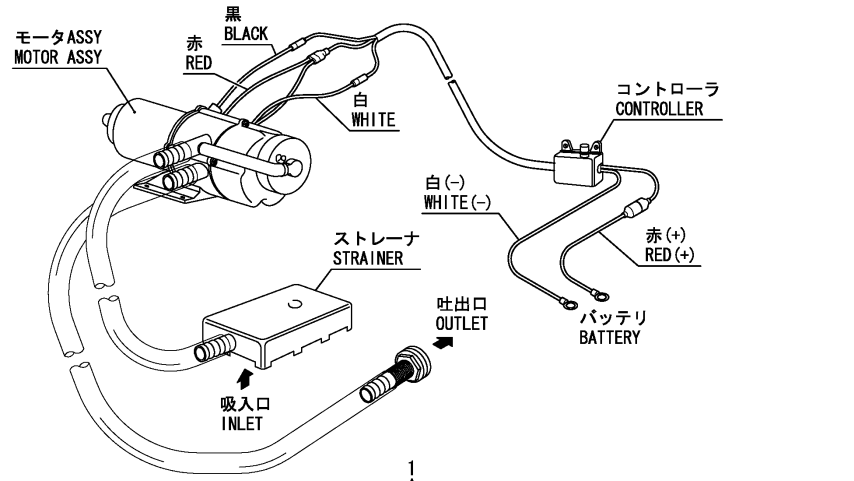

Fig.19. FUEL INJECTION PUMP

(A)=2YM15

(B)=

(C)=

(D)=

(E)=

(F)=

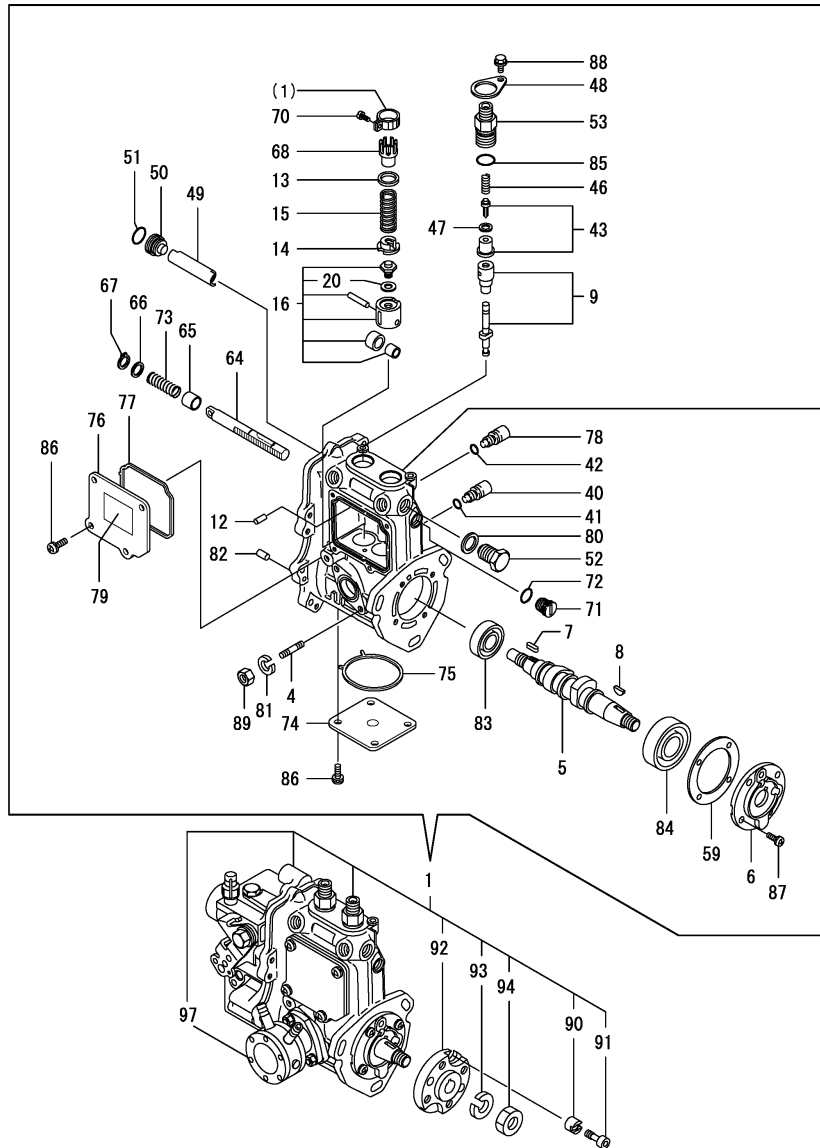

No.	Lev.	Parts No.	Description	Q'ty						I	R
				(A)	(B)	(C)	(D)	(E)	(F)		
1	1	728790-51350	PUMP ASSY, INJECTION	1							1
4	2	129155-51020	STUD	2							
5	2	119415-51030	CAMSHAFT, PUMP	1							
6	2	119717-51060	SUPPORT, CAMSHAFT	1							
7	2	119717-51070	KEY, PARALLEL	1							
8	2	122710-51090	KEY, FEATHER	1							
9	2	119415-51100	PLUNGER ASSY	2							
12	2	129155-51140	PIN, BARREL LOCK	2							
13	2	158600-51170	RETAINER, SPRING	2							
14	2	119717-51180	RETAINER, SPRING	2							
14-1	2	119717-51570	RETAINER, SPRING	2							R
(A=E/#E1807)											
15	2	119717-51190	SPRING, PLUNGER	2							
16	2	119717-51200	TAPPET ASSY, ROLLER	2							
16-1	2	119717-51201	TAPPET ASSY, ROLLER	2							N
(A=*2016.04.)											
20	3	129155-51600	SHIM SET, ADJUSTING	2							
40	2	158600-51270	STOPPER, TAPPET	2							
41	2	129155-51280	O-RING, S6	2							
42	2	129155-51280	O-RING, S6	1							
43	2	119717-51300	VALVE ASSY, DELIVERY	2							
46	2	119717-51330	SPRING, DELIVERY	2							
47	2	124550-51350	GASKET, DELIVERY	2							
48	2	118400-51370	PLATE, LOCK	2							
48-1	2	119125-51370	RETAINER, HOLDER	2							R
(A=*2010.09.)											
49	2	119415-51400	PROTECTOR	1							
50	2	158600-51410	PLUG, DEFLIFTER M12	1							
51	2	119717-51420	O-RING	1							
52	2	158600-51420	PLUG, DEFLIFTER M16	1							
53	2	158600-51441	VALVE ASSY, DELIVERY	2							
53-1	2	158600-51442	VALVE ASSY, DELIVERY	2							N
(A=E/#E1484)											
59	2	129155-51450	SHIM SET, ADJUSTING	1							
64	2	119415-51500	RACK, CONTROL	1							
65	2	129155-51521	BUSH, RACK	1							
65-1	2	119025-51520	BUSH,RACK	1							R
(A=*2011.08.)											
66	2	129155-51530	SPACER, SPRING	1							
67	2	129155-51540	CIRCLIP, C	1							
68	2	129155-51550	PINION, CONTROL	2							
70	2	129100-51570	SCREW, PINION M4	2							
71	2	158600-51570	PLUG, RACK	1							
72	2	129155-51580	O-RING	1							
73	2	129155-51591	SPRING, RACK ASSIST	1							
74	2	119415-51700	COVER, PUMP BOTTOM	1							
75	2	119415-51710	GASKET, PUMP	1							
76	2	119415-51750	COVER, BODY SIDE	1							
77	2	119415-51760	GASKET, PUMP COVER	1							
78	2	158600-51790	STOPPER, RACK	1							
79	2	129156-51910	LABEL, FIE CAUTION	1							

Remarks

(1)Governor(Fig.20) & Fuel Feed Pump(Fig.21) is incorporated in this Fuel Injection Pump(No.1).

Fig.19. FUEL INJECTION PUMP

(A)=2YM15
(B)=
(C)=

(D)=
(E)=
(F)=

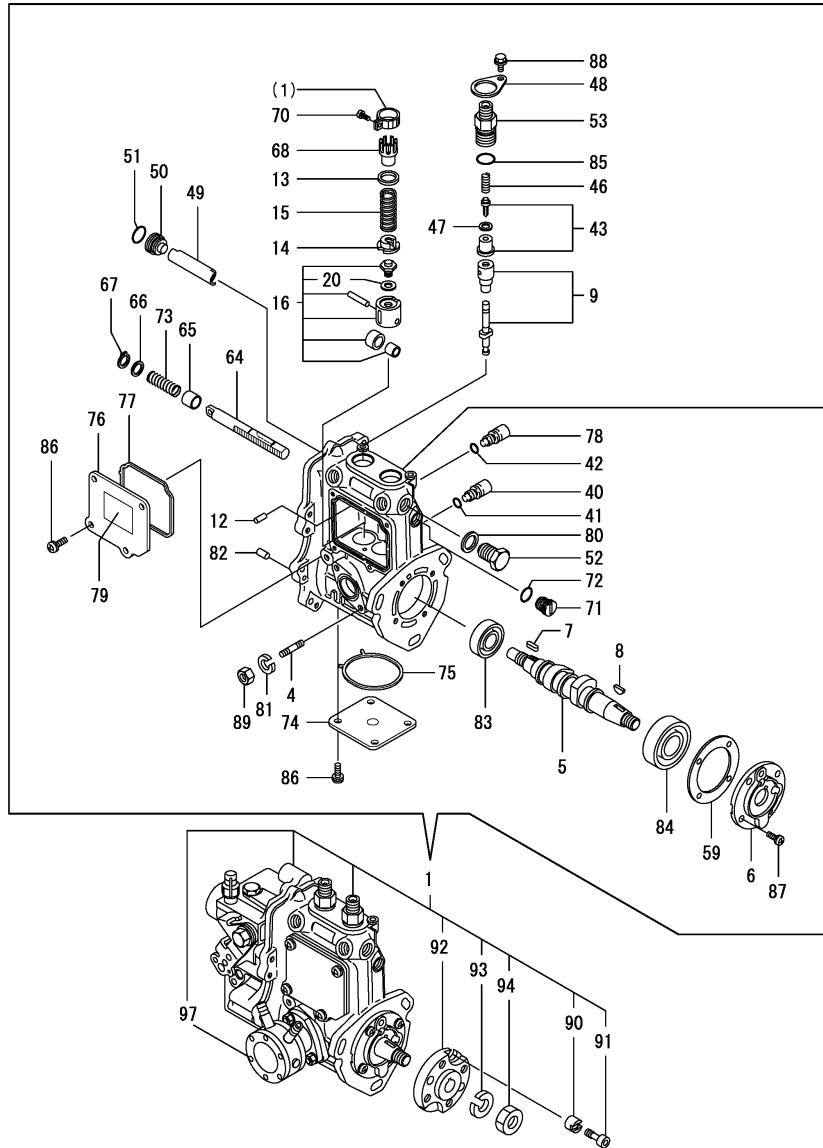

No.	Lev.	Parts No.	Description	Q'ty						I	R
				(A)	(B)	(C)	(D)	(E)	(F)		
80	2	22190-160002	WASHER, SEAL 16	1							
81	2	22217-060000	WASHER, SPRING 6	2							
82	2	22351-050010	PIN, SPRING 5.0X10	2							
83	2	24101-060034	BEARING, BALL 6003	1							
84	2	24101-063034	BEARING, BALL 6303	1							
85	2	24316-000150	O-RING, 4DP15.0	2							
86	2	26022-050122	SCREW, M5X12	8							
87	2	26022-060162	SCREW, M6X16	4							
87-1	2	119125-51900	BOLT, M6X14	4							R
(A=*2011.03.)											
88	2	26106-050102	BOLT, M5X 10 PLATED	2							
89	2	26716-060002	NUT, M6	2							
89-1	2	119717-51860	NUT, M6	2							N
(A=*2009.08.)											
90	2	119717-51480	COLLAR	1							
90-1	2	119717-51481	COLLAR, FIC FIX	1							N
(A=*2012.06.)											
91	2	119717-51490	BOLT	1							
91-1	2	119717-51491	BOLT, FIXATION	1							N
(A=*2012.06.)											
92	2	119717-51150	FLANGE, CAMSHAFT	1							
93	2	22217-120000	WASHER, SPRING 12	1							
94	2	26716-120002	NUT, M12	1							
97	2	129158-52000	PUMP ASSY, FUEL FEED	1							

Remarks

(1)Governor(Fig.20) & Fuel Feed Pump(Fig.21) is incorporated in this Fuel Injection Pump(No.1).

Fig.20. GOVERNOR

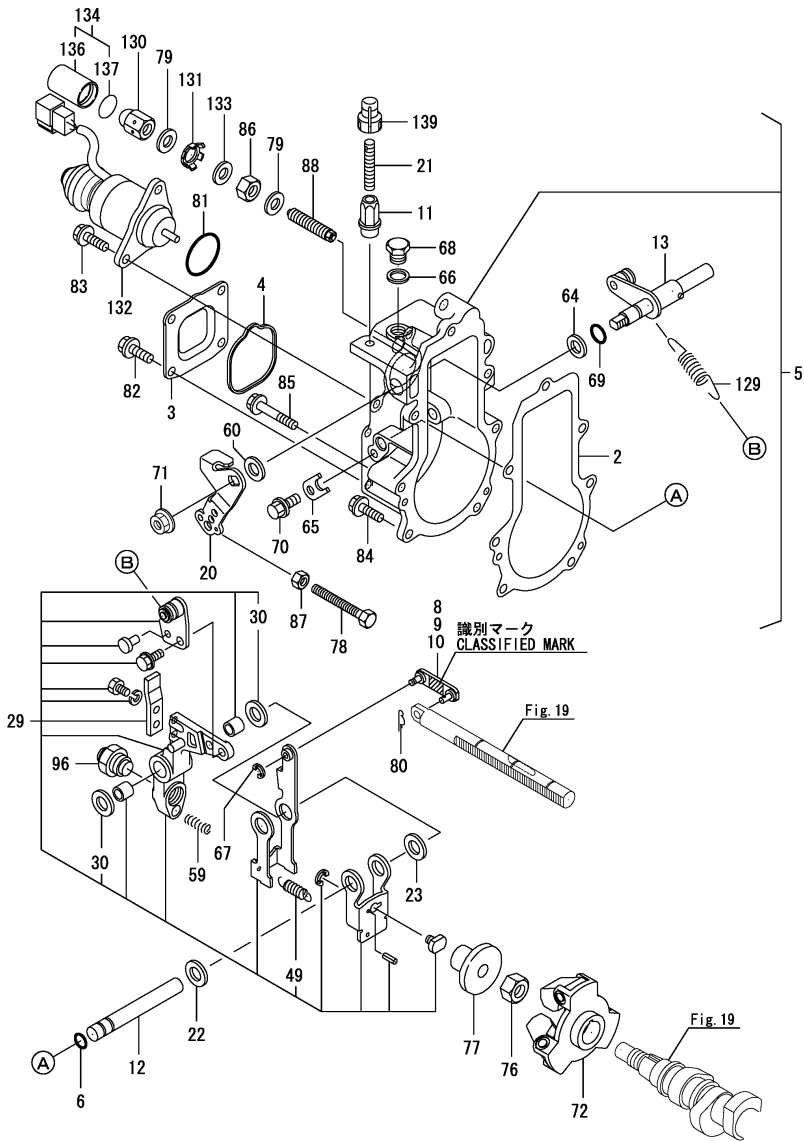

(A)=2YM15
(B)=
(C)=

(D)=
(E)=
(F)=

No.	Lev.	Parts No.	Description	Q'ty						I	R
				(A)	(B)	(C)	(D)	(E)	(F)		
2	2	119717-61050	GASKET, CASE	1							
3	2	119717-61060	COVER, GOVERNOR CASE	1							
4	2	119717-61070	GASKET, COVER	1							
5	2	119717-61100	CASE ASSY, GOVERNOR	1							
6	3	129155-51280	O-RING, S6	1							
8	3	119717-61120	LINK, L=29.3 MARK 3	1							1
9	3	119717-61130	LINK, L=29.8 MARK 98	1							1
10	3	119717-61140	LINK, L=28.8 MARK 88	1							1
10A	3	119717-61150	LINK, L=30.3 MARK 03	1							1
11	3	129209-61370	NUT, ARB M6	1							
12	3	129052-61390	SHAFT,GOVERNOR LEVER	1							
13	3	119717-61400	SHAFT ASSY, LEVER	1							
20	3	119515-61440	LEVER, CONTROL	1							
21	3	129155-61450	BOLT, LIMITER	1							
21-1	3	121575-66830	SCREW, ADJUSTER	1							R
(A=*2011.05.)											
22	3	129156-61460	SHIM, LEVER T=0.6	1							
23	3	129155-61480	SPACER ASSY, LEVER	1							
29	3	119717-61500	LEVER ASSY, GOVERNOR	1							
30	4	174307-51700	SHIM SET, PLUNGER	2							
49	4	129486-61540	SPRING, LEVER	1							
59	3	129100-61650	SPRING, FUEL LIMITER	1							
60	3	158552-61700	SHIM SET	1							
64	3	158552-61710	SHIM, T=1.0	1							
65	3	119660-61901	STOPPER, SHAFT	1							
66	3	22190-100002	WASHER, SEAL 10	1							
67	3	22272-000030	RING, E- 3	1							
68	3	23887-100002	PLUG, 10	1							
68-1	3	119717-51930	PLUG, M10	1							R
(A=*2011.02.)											
69	3	24341-000070	O-RING, 1AS7.0	1							
70	3	26106-060102	BOLT, M6X 10 PLATED	1							
71	3	26366-080002	NUT, M8	1							
72	2	119717-61200	WEIGHT ASSY,GOVERNOR	1							
72-1	2	119717-61201	WEIGHT ASSY,GOVERNOR	1							R
(A=E/#E3948)											
76	2	119660-61300	NUT, SUPPORT	1							
76-1	2	129008-61301	NUT, SUPPORT	1							R
(A=E/#E3237)											
77	2	129155-61341	SLEEVE	1							
78	2	129155-61460	BOLT, IDLE LIMIT	1							
78-1	2	129155-61461	BOLT,IDLE LIMIT	1							N
(A=*2016.02.)											
79	2	22190-120002	WASHER, SEAL 12	2							
80	2	22372-040000	PIN, SNAP 4	1							
81	2	24341-000280	O-RING, 1AS28.0	1							
81-1	2	158552-61900	O-RING	1							N
(A=E/#E1747)											
82	2	26106-060102	BOLT, M6X 10 PLATED	4							
83	2	26106-060142	BOLT, M6X 14 PLATED	2							
84	2	26106-060202	BOLT, M6X 20 PLATED	4							

Remarks

- (1) Selective parts.
Certain the classification mark, then place your order(Refer to illustration).
- (2) Spare parts.

Fig.20. GOVERNOR

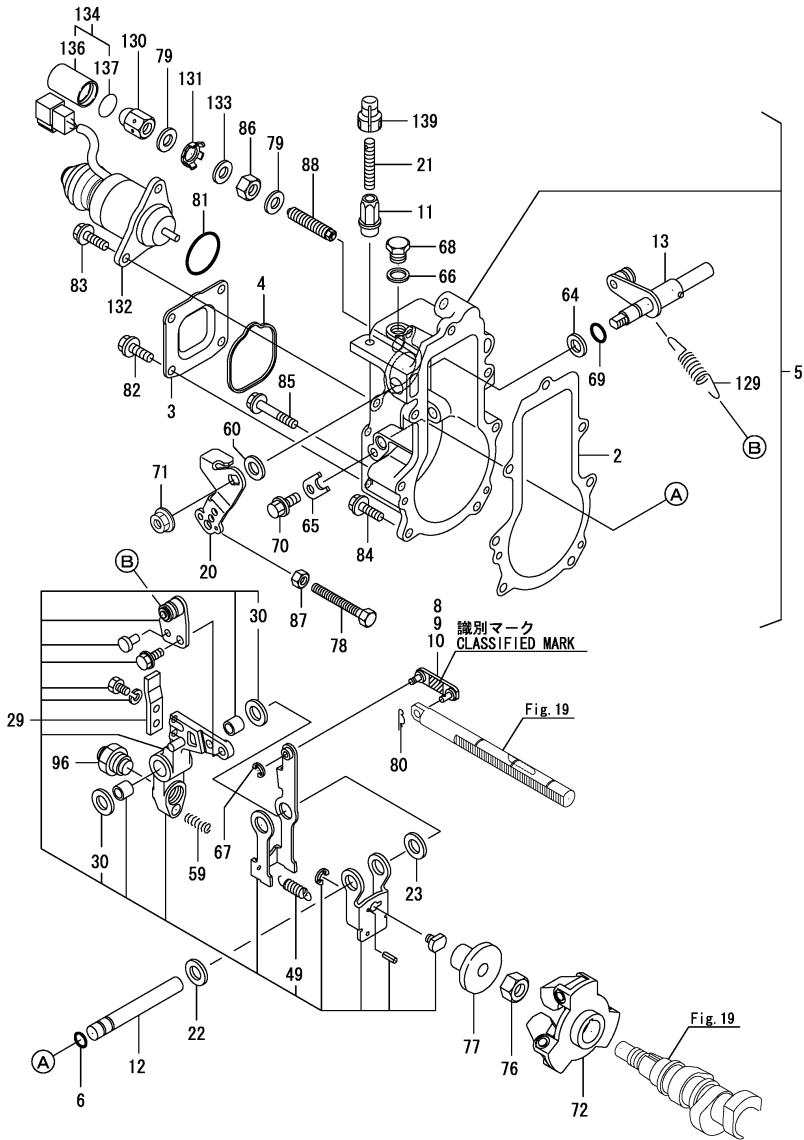

(A)=2YM15

(B)=

(C)=

(D)=

(E)=

(F)=

No.	Lev.	Parts No.	Description	Q'ty						I	R
				(A)	(B)	(C)	(D)	(E)	(F)		
85	2	26106-060452	BOLT, M6X 45 PLATED	3							
86	2	26736-120002	NUT, M12	1							
86-1	2	129209-61920	NUT, ARB	1							R
(A=#E3151)											
87	2	26756-060002	NUT, LOCK M6	1							
87-1	2	119740-61470	NUT	1							N
(A=*2017.03.)											
88	2	158601-61760	LIMITER ASSY, FUEL	1							
88-1	2	158601-61710	LIMITER ASSY, FUEL	1							S
(A=*2012.11.)											
96	2	128990-61560	ANGLEICH ASSY	1							
129	2	119527-61700	SPRING, GOVERNOR	1							
130	2	129209-61930	NUT	1							
131	2	129209-61970	LABEL	1							
132	2	129271-77950	SOLENOID, STOP	1							
133	2	23414-120016	GASKET, 12X1.0	1							
134	1	129209-61940	CASE ASSY	1							
136	2	129209-61960	CASE	1							2
136-1	2	129209-61961	CASE	1							S 2
(A=#E7170)											
137	2	24311-000150	O-RING, 1AP15.0	1							
137-1	2	24311-000160	O-RING, 1AP16.0	1							S
(A=#E7170)											
139	1	119285-66650	CAP, HIGH-IDLE	1							2

Remarks

- (1) Selective parts.
Certain the classification mark, then place your order(Refer to illustration).
- (2) Spare parts.

Fig.21. FUEL FEED PUMP

(A)=2YM15
(B)=
(C)=

(D)=
(E)=
(F)=

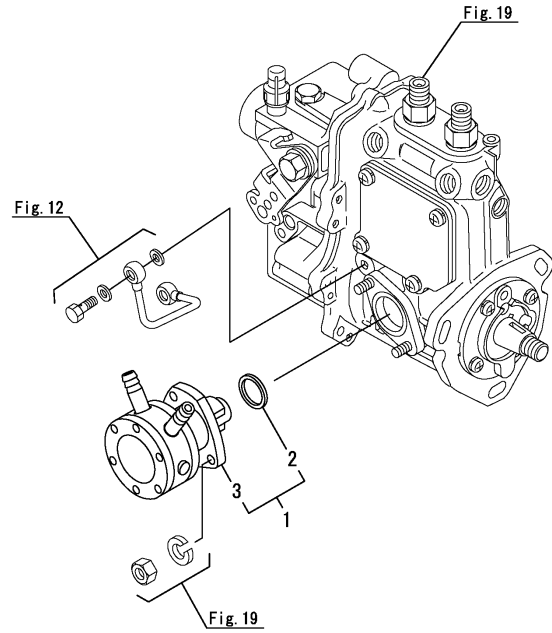

No.	Lev.	Parts No.	Description	Q'ty						I	R
				(A)	(B)	(C)	(D)	(E)	(F)		
1	2	129158-52000	PUMP ASSY, FUEL FEED	1							
2	3	129155-52051	GASKET, PUMP COVER	1							
3	3	129158-52101	PUMP ASSY, FUEL FEED	1							

Fig.22. FUEL INJECTION VALVE & FUEL INJECTION PIPE

(A)=2YM15
(B)=
(C)=

(D)=
(E)=
(F)=

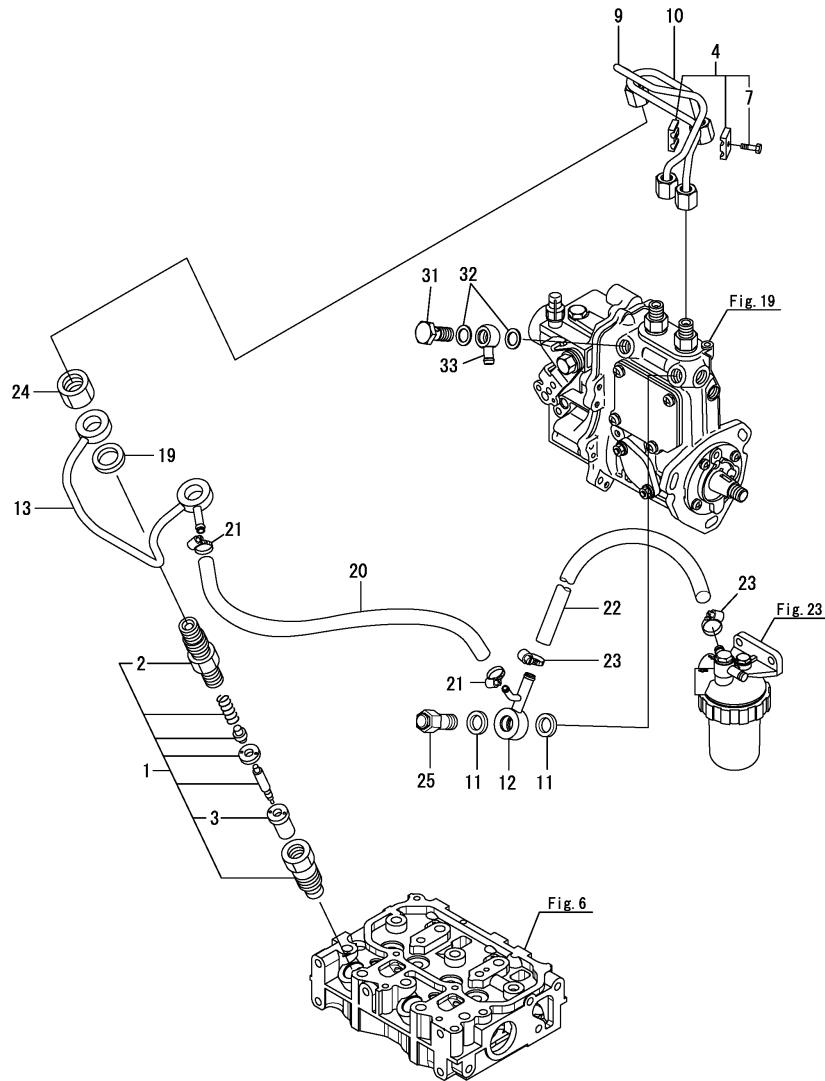

No.	Lev.	Parts No.	Description	Q'ty						I	R
				(A)	(B)	(C)	(D)	(E)	(F)		
1	1	119515-53001	VALVE ASSY,INJECTION	2							
2	2	118200-53010	HOLDER, NOZZLE	2							
3	2	119515-53010	VALVE ASSY,INJECTION	2							
3A	2	129901-53800	SHIM SET, ADJUSTING	2							1
4	1	119305-59120	RETAINER, PIPE	1							
7	2	129150-59131	BOLT, M4X14	1							
9	1	119415-59810	PIPE, INJECTION NO.1	1							
10	1	119415-59820	PIPE, INJECTION NO.2	1							
11	1	22190-120002	WASHER, SEAL 12	2							
12	1	119840-59570	JOINT, OVERFLOW	1							
13	1	119415-59540	PIPE ASSY, RETURN	1							
19	1	129901-59560	GASKET, FUEL RETURN	2							
20	1	119773-59511	PIPE, FUEL	1							
20-1	1	128990-59510	PIPE, FUEL	1							N
(A=E/#E7170)											
21	1	23000-016000	CLAMP, 16	2							
22	1	128890-59040	PIPE, FUEL	1							
22-1	1	128890-59041	PIPE, FUEL	1							R
(A=E/#E7170)											
23	1	23000-016000	CLAMP, 16	2							
23-1	1	23000-013000	CLAMP, 13	2							N
(A=E/#E7170)											
24	1	119620-59700	NUT, NOZZLE RETURN	2							
25	1	119813-59950	VALVE ASSY, CHECK	1							
31	1	103854-39140	BOLT, PIPE JOINT	1							
32	1	22190-120002	WASHER, SEAL 12	2							
33	1	101304-59020	JOINT, PIPE 12	1							

Remarks
(1)Service parts.

Fig.23. FUEL PIPE & FUEL FILTER

(A)=2YM15

(B)=

(C)=

(D)=

(E)=

(F)=

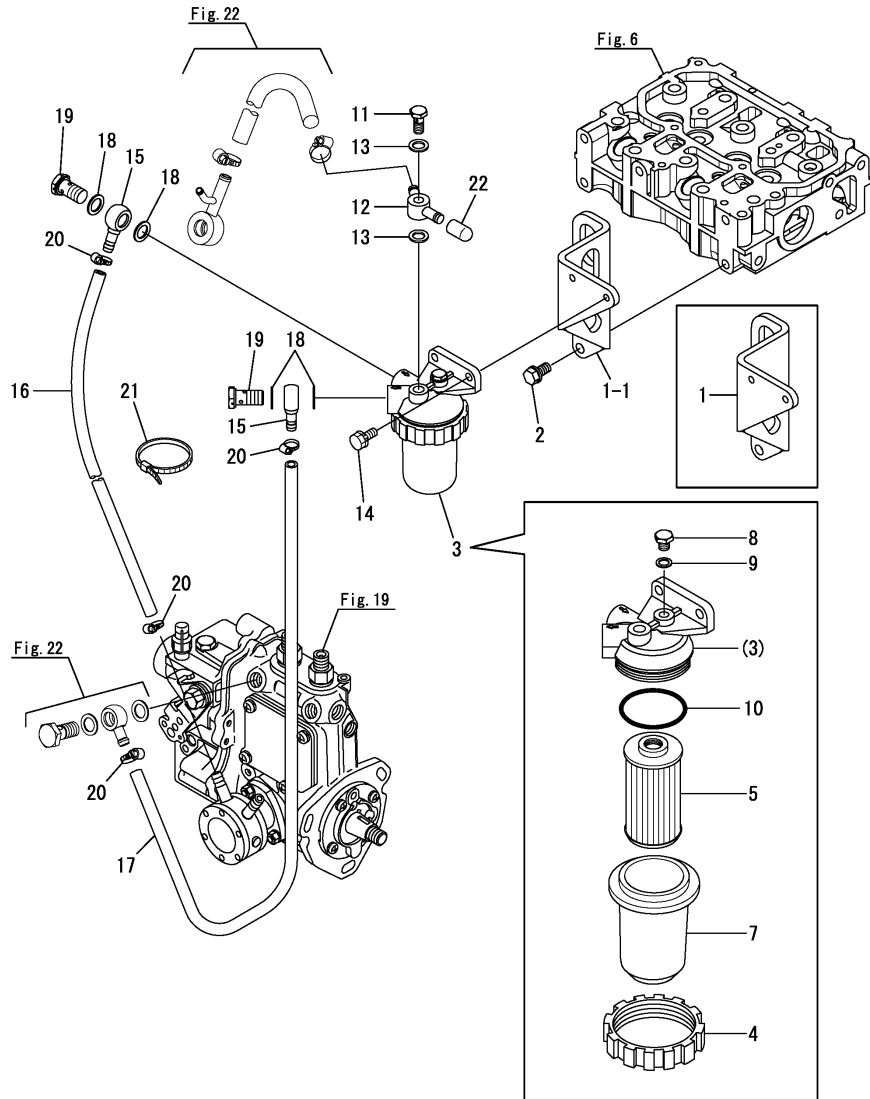

No.	Lev.	Parts No.	Description	Q'ty						I	R
				(A)	(B)	(C)	(D)	(E)	(F)		
1	1	128990-55010	BRACKET, FILTER	1							
1-1	1	128990-55011	BRACKET, FILTER	1							N
(A=E/#E0407)											
2	1	26106-080162	BOLT, M8X 16 PLATED	2							
3	1	121370-55601	STRAINER ASSY, FUEL	1							
4	2	110250-55610	RING, CUP RETAINING	1							
5	2	104500-55710	ELEMENT, FUEL FILTER	1							
7	2	121370-55730	CUP, STRAINER	1							
8	2	101720-55750	PLUG, HEXAGON M6	1							
9	2	23418-060000	GASKET, 6X1.0	1							
10	2	24341-000440	O-RING, 1AS44.0	1							
11	1	128990-59150	BOLT, PIPE JOINT M8	1							
12	1	128990-59530	JOINT, RETURN PIPE	1							
13	1	22190-080002	WASHER, SEAL 8	2							
14	1	26013-060162	BOLT, M6X 16	2							
15	1	104264-59020	JOINT	2							
16	1	128890-59050	PIPE, FUEL	1							
16-1	1	128890-59051	PIPE, FUEL	1							N
(A=E/#E7170)											
17	1	128890-59060	PIPE, FUEL	1							
17-1	1	128890-59061	PIPE, FUEL	1							N
(A=E/#E7170)											
18	1	22190-120002	WASHER, SEAL 12	4							
19	1	23857-060000	BOLT, JOINT 6	2							
20	1	23000-016000	CLAMP, 16	4							
21	1	121750-59890	BAND, NYLON	1							W
(A=*2010.07.)											
21-1	1	128990-59890	BAND, 200	1							R
(A=E/#E7170)											
22	1	128990-59900	CAP, FUEL IN/OUT	2							W
(A=E/#E7253)											

Fig.46. (23A)WATER SEPARATOR

(A)=2YM15
(B)=
(C)=

(D)=
(E)=
(F)=

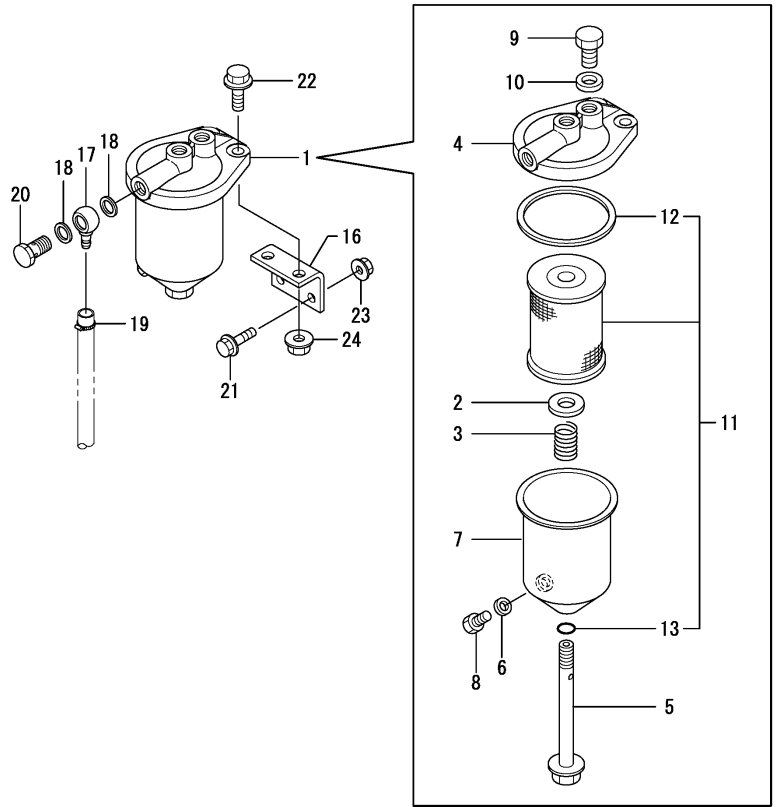

No.	Lev.	Parts No.	Description	Q'ty						I	R
				(A)	(B)	(C)	(D)	(E)	(F)		
1	1	129670-55750 (A=E/#E7253)	SEPARATOR ASSY,WATER	1							W
2	2	123325-35160	SEAT, SPRING	1							
3	2	123325-35170	SPRING, FILTER	1							
4	2	129495-55610	BODY, STRAINER	1							
5	2	129495-55620	BOLT, CENTER	1							
6	2	123672-55760	GASKET	1							
7	2	129065-55760	CASE, SEPARATOR	1							
8	2	129065-55770	PLUG, DRAIN M8	1							
9	2	129065-55800	PLUG, M14	1							
10	2	123678-55890	GASKET, PLUG	1							
11	2	41650-502320	ELEMENT ASSY, FUEL	1							
12	3	123325-35140	GASKET, COVER	1							
13	3	24311-000120	O-RING, 1AP12.0	1							
16	1	129670-55810	PLATE, SEPARATOR	1							
17	1	121750-59910	JOINT, BALL 14	2							
18	1	22190-140002	WASHER, SEAL 14	4							
19	1	23000-013000	CLAMP, 13	2							
20	1	23857-080000	BOLT, JOINT 8	2							
21	1	26106-080302	BOLT, M8X 30 PLATED	2							
22	1	26106-100302	BOLT, M10X 30 PLATED	2							
23	1	26366-080002	NUT, M8	2							
24	1	26366-100002	NUT, M10	2							

Fig.25. BRACKET(CABLE)

(A)=2YM15
(B)=
(C)=

(D)=
(E)=
(F)=

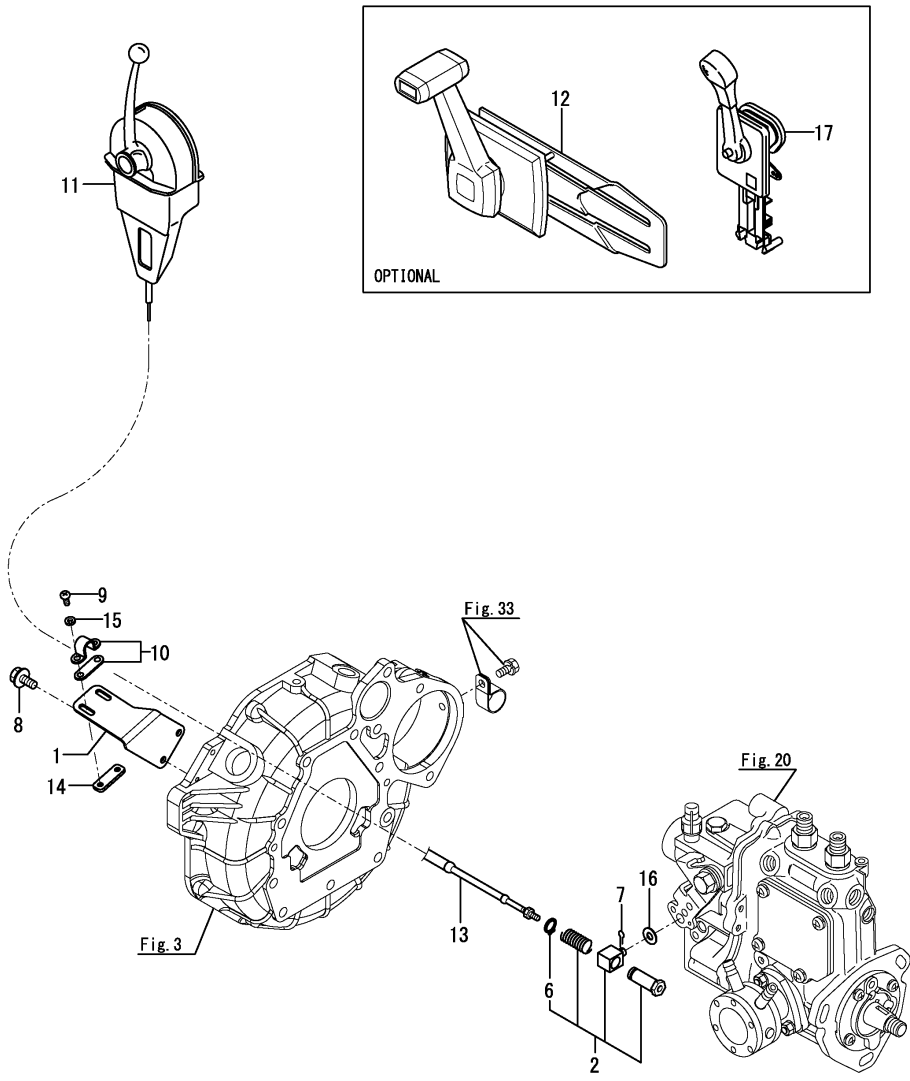

No.	Lev.	Parts No.	Description	Q'ty						I	R
				(A)	(B)	(C)	(D)	(E)	(F)		
1	1	128790-67150	BRACKET, CABLE	1							
2	1	129470-67200	RETAINER ASSY	1							
6	2	22242-000100	RING, 10	1							
7	1	22360-080000	SNAP PIN 8	1							
7-1	1	22414-250150	PIN, COTTER 2.5X15	1							N
(A=E/#E7170)											
8	1	26106-060102	BOLT, M6X 10 PLATED	2							
8-1	1	26106-060122	BOLT, M6X 12 PLATED	2							R
(A=E/#E7170)											
9	1	26557-050202	SCREW, M5X20	2							
10	1	41710-000410	CLAMP	1							
11	1	41730-000681	CONTROL, MT-3	1							
12	1	128170-86501	REMOCON HEAD (MN)	1							
13	1	41710-000380	CABLE, PP 33CX4M	2							
13-1	1	27730-301400	CABLE, REMO-CON	2							R
(A=*2012.09.)											
14	1	121574-86320	RETAINER	1							
15	1	22212-050000	WASHER 5	2							
15-1	1	22217-050000	WASHER, SPRING 5	2							R
(A=E/#E7253)											
16	1	22117-080000	WASHER, 8	1							W
(A=E/#E7170)											
17	1	129677-86500	CONTROL HEAD,SIDE MO	1							

Fig.26. CLUTCH

(A)=2YM15
(B)=
(C)=

(D)=
(E)=
(F)=

No.	Lev.	Parts No.	Description	Q'ty						I	R
				(A)	(B)	(C)	(D)	(E)	(F)		
1	1	128171-81520	CLUTCH, I=2.62	1							
2	1	128171-81510	CLUTCH, I=2.21	1							
3	1	128171-81530	CLUTCH, I=3.22	1							
4	1	26106-080422	BOLT, M8X 42 PLATED	7							
4-1	1	26106-080402	BOLT, M8X 40 PLATED	7							R
		(A=*2008.03.)									
5	1	26216-080452	STUD, M8X 45	1							
6	1	26366-080002	NUT, M8	1							

この項目には、イラスト表現はしていません。

The parts of this figure are not illustrated.

Fig.27. CLUTCH REMOTE CONTROL

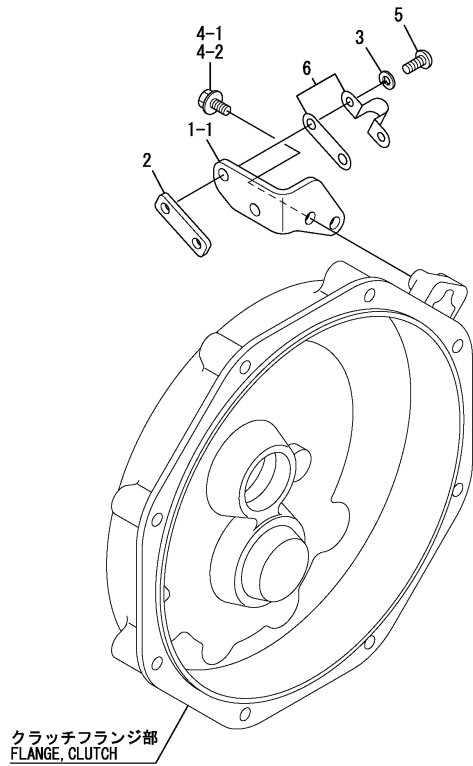

(A)=2YM15
(B)=
(C)=

(D)=
(E)=
(F)=

No.	Lev.	Parts No.	Description	Q'ty						I	R
				(A)	(B)	(C)	(D)	(E)	(F)		
1	1	128990-86301	BRACKET, CABLE	1							
1-1	1	128990-86310	BRACKET, CABLE	1						F	1
(A=E/#E6392)											
2	1	121574-86320	RETAINER	1							
3	1	22212-050000	WASHER 5	2							
3-1	1	22217-050000	WASHER, SPRING 5	2							R
(A=E/#E7253)											
4	1	26106-060452	BOLT, M6X 45 PLATED	2							
4-1	1	26106-060142	BOLT, M6X 14 PLATED	2						F	1
(A=E/#E6392)											
4-2	1	26106-060122	BOLT, M6X 12 PLATED	2							R
(A=*2008.03.)											
5	1	26557-050202	SCREW, M5X20	2							
6	1	41710-000410	CLAMP	1							
7	1	128990-86350	SPACER, BRACKET	2							Z
(A=E/#E6392)											

Remarks
(1)No.1-1 & 4-1 interchangeable by set.

Fig.28. COUPLING(OPTIONAL)

テーパカップリング
TAPER COUPLING

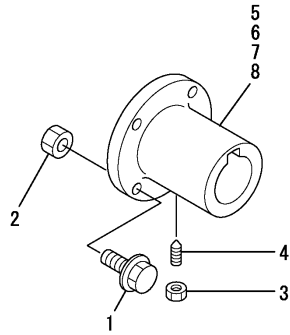

ストレートカップリング
STRAIGHT COUPLING

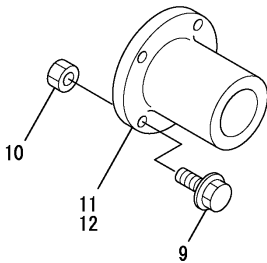

スリットカップリング
SLIT COUPLING

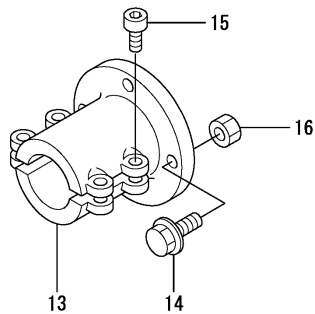

No.	Lev.	Parts No.	Description	Q'ty						I	R
				(A)	(B)	(C)	(D)	(E)	(F)		
1	1	26106-100322	BOLT, M10X 32 PLATED	4							
2	1	26706-100002	NUT, M10	4							
3	1	26756-080002	NUT, LOCK M8	1							
4	1	48110-032411	BOLT, LOCK	1							
5	1	48110-522361	COUPLING, TAPER 22	1							
6	1	48110-025063	COUPLING, TAPER 25	1							
7	1	48110-028063	COUPLING, TAPER 28	1							
8	1	48110-032502	COUPLING, TAPER 30	1							
9	1	26106-100322	BOLT, M10X 32 PLATED	4							
10	1	26706-100002	NUT, M10	4							
11	1	45414-500260	COUPLING, 16	1							
12	1	105583-85900	COUPLING, 22	1							
13	1	104214-83980	COUPLING, SLIT 20	1							
14	1	26106-100322	BOLT, M10X 32 PLATED	4							
15	1	26450-080282	BOLT, M8X 28	4							
15-1	1	26450-080302	BOLT, M8X 30	4							R
		(A=*2008.03.)									
16	1	26706-100002	NUT, M10	4							

Fig.29. STARTER MOTOR

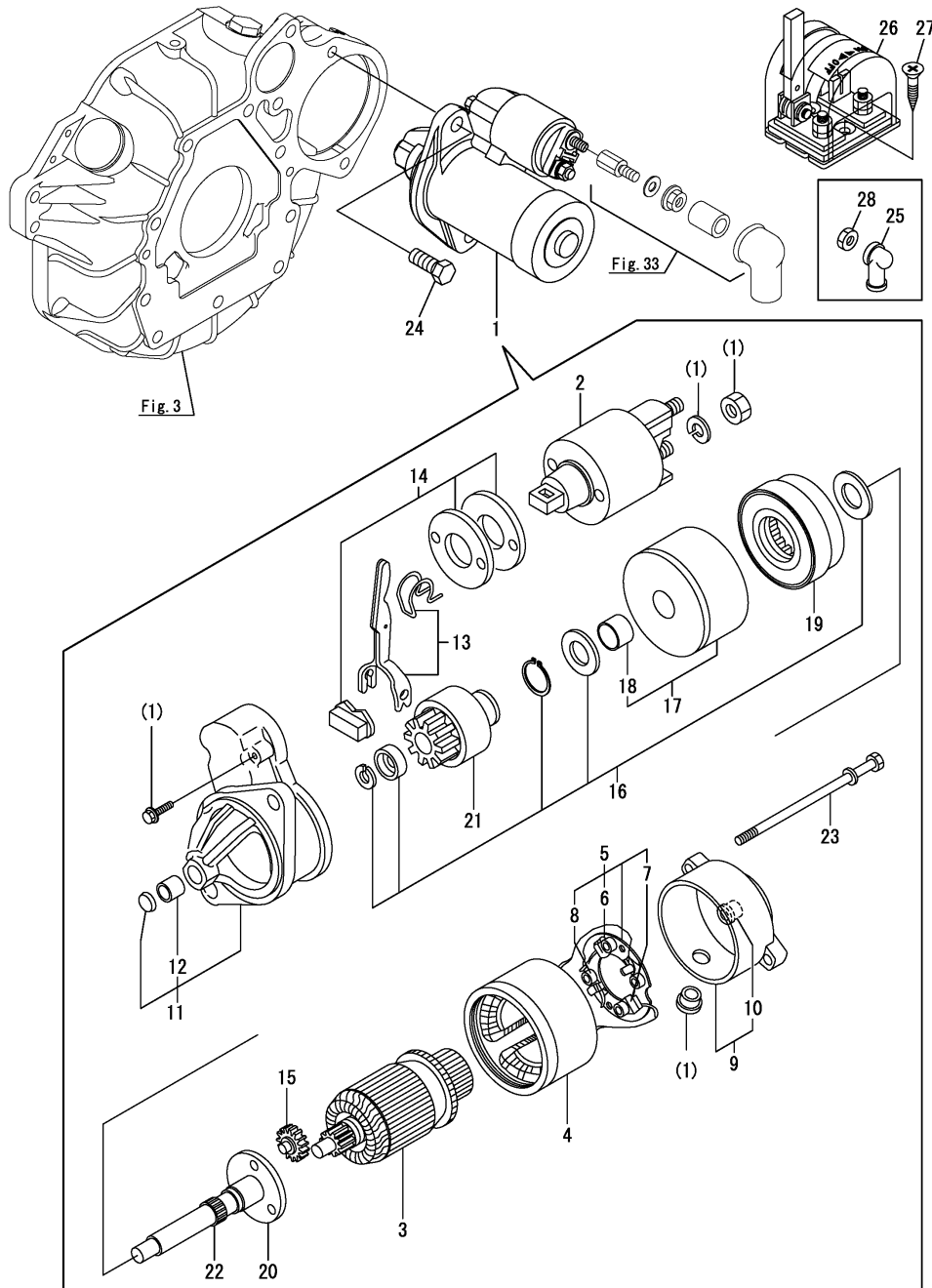

(A)=2YM15

(B)=

(C)=

(D)=

(E)=

(F)=

No.	Lev.	Parts No.	Description	Q'ty						I	R
				(A)	(B)	(C)	(D)	(E)	(F)		
1	1	129608-77010	STARTER ASSY	1							
2	2	129698-77020	SWITCH ASSY, MAGNET	1							
3	2	129698-77101	ARMATURE ASSY	1							
4	2	129608-77110	YOKE ASSY	1							
5	2	129698-77120	HOLDER ASSY, BRUSH	1							
6	3	129698-77140	BRUSH SET	1							
7	3	129698-77130	BRUSH	2							
8	3	129698-77150	SPRING, BRUSH	4							
9	2	129698-77161	COVER ASSY, STARTER	1							
10	3	129698-77170	BEARING, REAR COVER	1							
11	2	129698-77260	CASE ASSY, GEAR	1							
12	3	X2114535200	METAL, STARTER	1							
13	2	129698-77270	LEVER SET, SHIFT	1							
14	2	129698-77280	COVER KIT, DUST	1							
15	2	129698-77240	GEAR, PLANETARY	3							
16	2	129698-77250	WASHER SET	1							
17	2	129698-77180	BRACKET, CENTER P	1							
18	3	129698-77190	BRACKET, CENTER	1							
19	2	129698-77200	GEAR, INTERNAL	1							
20	2	129698-77210	BRACKET, CENTER A	1							
21	2	129698-77220	PINION ASSY	1							
22	2	129698-77230	SHAFT, PINION	1							
23	2	124195-77770	BOLT, THROUGH	2							
24	1	26116-120302	BOLT, M12X 30 PLATED	2							
25	1	124550-77030	COVER, TERMINAL B	1							
25-1	1	129670-77030	COVER, TERMINAL B	1							R
(A=*2008.02.)											
25-2	1	129670-77030	COVER, TERMINAL B	1							Z
(A=E/#E8144)											
26	1	123310-77640	SWITCH, BATTERY	1							
27	1	22724-800380	SCREW, 8.0X38	2							
28	1	26756-080002	NUT, LOCK M8	1							Z
(A=E/#E8144)											

Fig.30. GENERATOR(HITACHI/60A)(UP TO SEP. 2010)

(A)=2YM15
(B)=
(C)=

(D)=
(E)=
(F)=

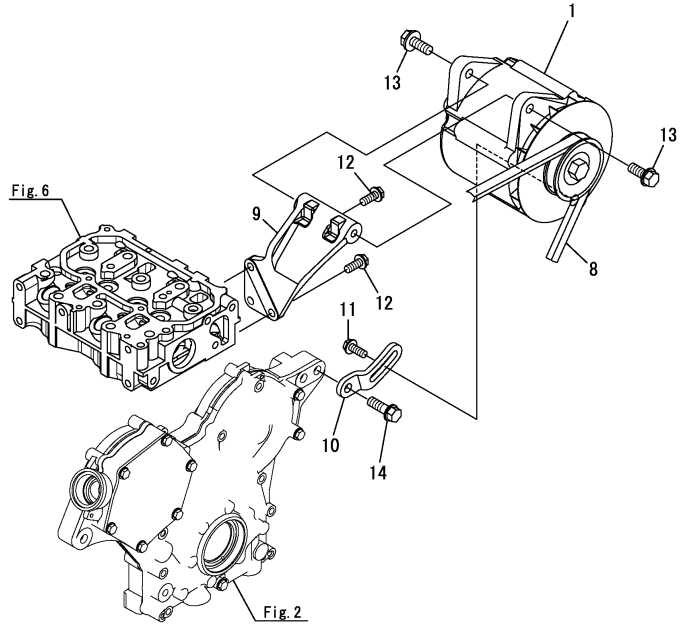
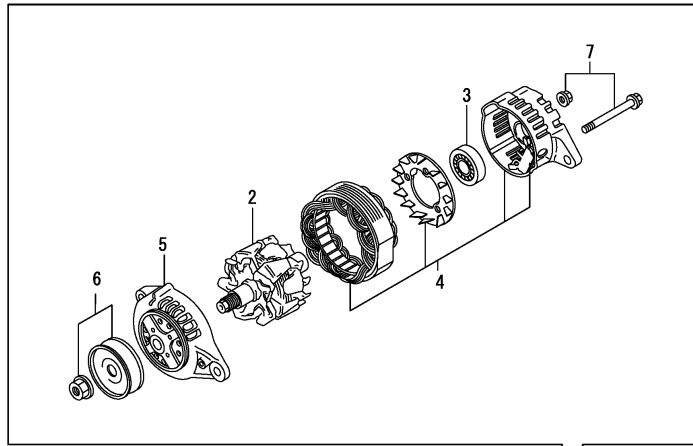

No.	Lev.	Parts No.	Description	Q'ty						I	R
				(A)	(B)	(C)	(D)	(E)	(F)		
1	1	128271-77200	GENERATOR, 12V-60A	1							Z
		(A=*2010.09.)									
2	2	123900-77700	ROTOR ASSY	1							
3	2	129612-77710	BEARING, BALL	1							
4	2	128271-77720	BRACKET(STATOR+REGUL	1							
5	2	123900-77730	BRACKET ASSY, FRONT	1							
6	2	128271-77740	PULLEY	1							
7	2	128271-77750	SCREW KIT	1							
8	1	129612-42290	V-BELT, A37.5	1							Z
		(A=*2010.09.)									
9	1	128890-77310	BRACKET, ALTERNATOR	1							Z
		(A=*2010.09.)									
10	1	128990-77330	ADJUSTER, BELT	1							Z
		(A=*2010.09.)									
11	1	26106-080202	BOLT, M8X 20 PLATED	1							Z
		(A=*2010.09.)									
12	1	26106-080252	BOLT, M8X 25 PLATED	3							Z
		(A=*2010.09.)									
13	1	26106-100252	BOLT, M10X 25 PLATED	2							Z
		(A=*2010.09.)									
14	1	26106-100302	BOLT, M10X 30 PLATED	1							Z
		(A=*2010.09.)									

Remarks
 * This item was abolished.
 * Refer to Fig.39 for the combination of generator, wire harness, and panel.

Fig.31. GENERATOR(HITACHI/80A)(UP TO E/#E5887)

(A)=2YM15
(B)=
(C)=

(D)=
(E)=
(F)=

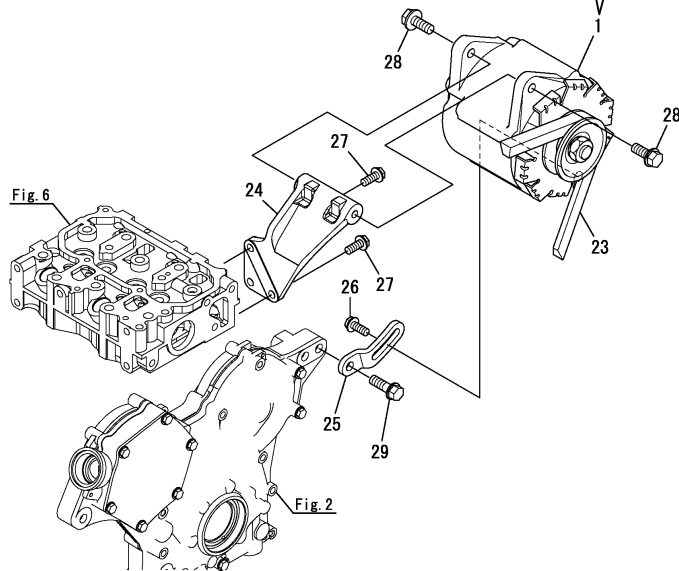
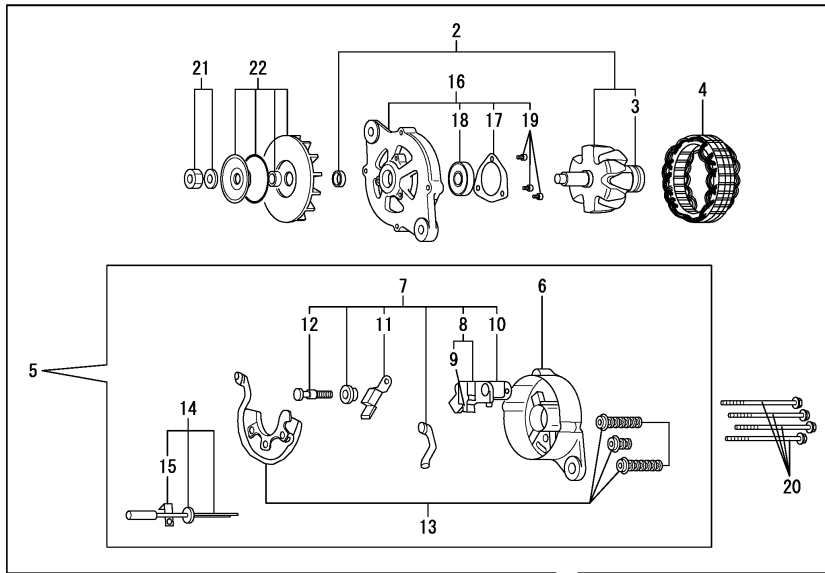

No.	Lev.	Parts No.	Description	Q'ty						I	R
				(A)	(B)	(C)	(D)	(E)	(F)		
1	1	119573-77201	ALTERNATOR, 12V-80A	1							Z
		(A=E/#E5887)									
2	2	XL180G61000	ROTOR ASSY	1							
3	3	119129-77320	BEARING, BALL	1							
4	2	XL180120000	STATOR ASSY	1							
5	2	XL180G63006	COVER ASSY, REAR	1							
6	3	XL180G13012	COVER, REAR	1							
7	3	XL180G43150	BRUSH ASSY,REGULATOR	1							
8	4	XL155G1330	BRUSH ASSY	1							
9	5	XL225G1325	BRUSH SET	2							
10	4	124080-77390	REGULATOR ASSY	1							
11	4	XL225431800	CONDENSER ASSY	1							
12	4	124080-77520	BOLT, M5	2							
13	3	XL1808320	DIODE ASSY	1							
14	3	119129-77250	WIRE, LEAD	1							
15	4	119129-77260	CLAMP	1							
16	2	XL235340110	COVER ASSY, FRONT	1							
17	3	XL150M14041	RETAINER	1							
18	3	X6303BM0000	BEARING, BALL	1							
19	3	119129-77930	SCREW KIT	1							
20	2	119129-77890	BOLT, THROUGH	4							
21	2	119129-77900	NUT ASSY, PULLEY	1							
22	2	XL180G85001	PULLEY ASSY	1							
23	1	129612-42290	V-BELT, A37.5	1							
24	1	128890-77310	BRACKET, ALTERNATOR	1							
25	1	128990-77330	ADJUSTER, BELT	1							
26	1	26106-080202	BOLT, M8X 20 PLATED	1							
27	1	26106-080252	BOLT, M8X 25 PLATED	3							
28	1	26106-100252	BOLT, M10X 25 PLATED	2							
29	1	26106-100302	BOLT, M10X 30 PLATED	1							

Remarks

* This item is applicable to [(A)=E/#E5887] or previous machines(Refer to Fig.37).
* Refer to Fig.39 for the combination of generator, wire harness, and panel.

Fig.37. (31A)GENERATOR(VALEO)(FROM E/#E5888)

(A)=2YM15
(B)=
(C)=

(D)=
(E)=
(F)=

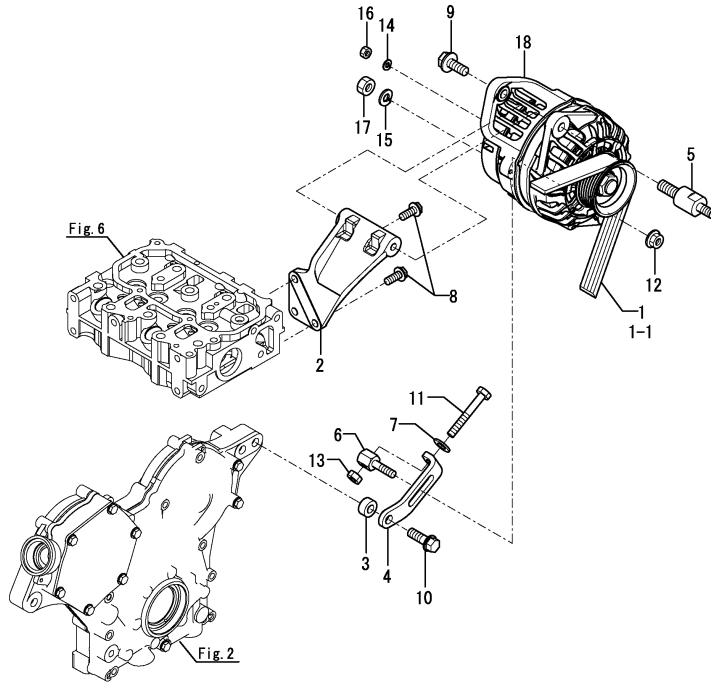

No.	Lev.	Parts No.	Description	Q'ty						I	R
				(A)	(B)	(C)	(D)	(E)	(F)		
1	1	128790-77580	BELT, ALTERNATOR 6PK	1							
1-1	1	128790-77600	BELT,ALTERNATOR 6PK	1						S	2
(A=EE8848)											
2	1	128890-77310	BRACKET, ALTERNATOR	1							
3	1	128990-77320	SPACER, ADJUSTER	1							
4	1	128990-77341	ADJUSTER, BELT	1							
5	1	128990-77410	BOLT, BELT COVER	1							
6	1	129271-77641	BOLT, ADJUSTER	1							
7	1	22137-080000	WASHER, 8	1							
8	1	26106-080252	BOLT, M8X 25 PLATED	3							
9	1	26106-100302	BOLT, M10X 30 PLATED	1							
10	1	26106-100402	BOLT, M10X 40 PLATED	1							
11	1	26116-080604	BOLT, M8X 60 PLATED	1							
12	1	26366-080002	NUT, M8	1							
13	1	26716-080002	NUT, M8	1							
14	1	22217-050000	WASHER, SPRING 5	2							
15	1	22217-080000	WASHER, SPRING 8	1							
16	1	26716-050002	NUT, M5	2							
17	1	26716-080002	NUT, M8	1							
17-1	1	26756-080002	NUT, LOCK M8	1							N
(A=E/#E7170)											
18	1	128990-77250	ALTERNATOR, 12V-125A	1							W 1
(A=E/#E5888)											

Remarks

* This item is applicable to [(A)=E/#E5888] or following machines(Refer to Fig.31).

* Refer to Fig.39 for the combination of generator, wire harness, and panel.

(1)Inner parts are shown in Fig.42.

(2)Length of belt =No.1 : 995mm, No.1-1 : 940mm.

No.1-1 is interchangeable with a set of Fig.10 No.11-1, Fig.14 No.47-2 & Fig.38 No.1-5.

Fig.42. (31B)GENERATOR(INNER PARTS)

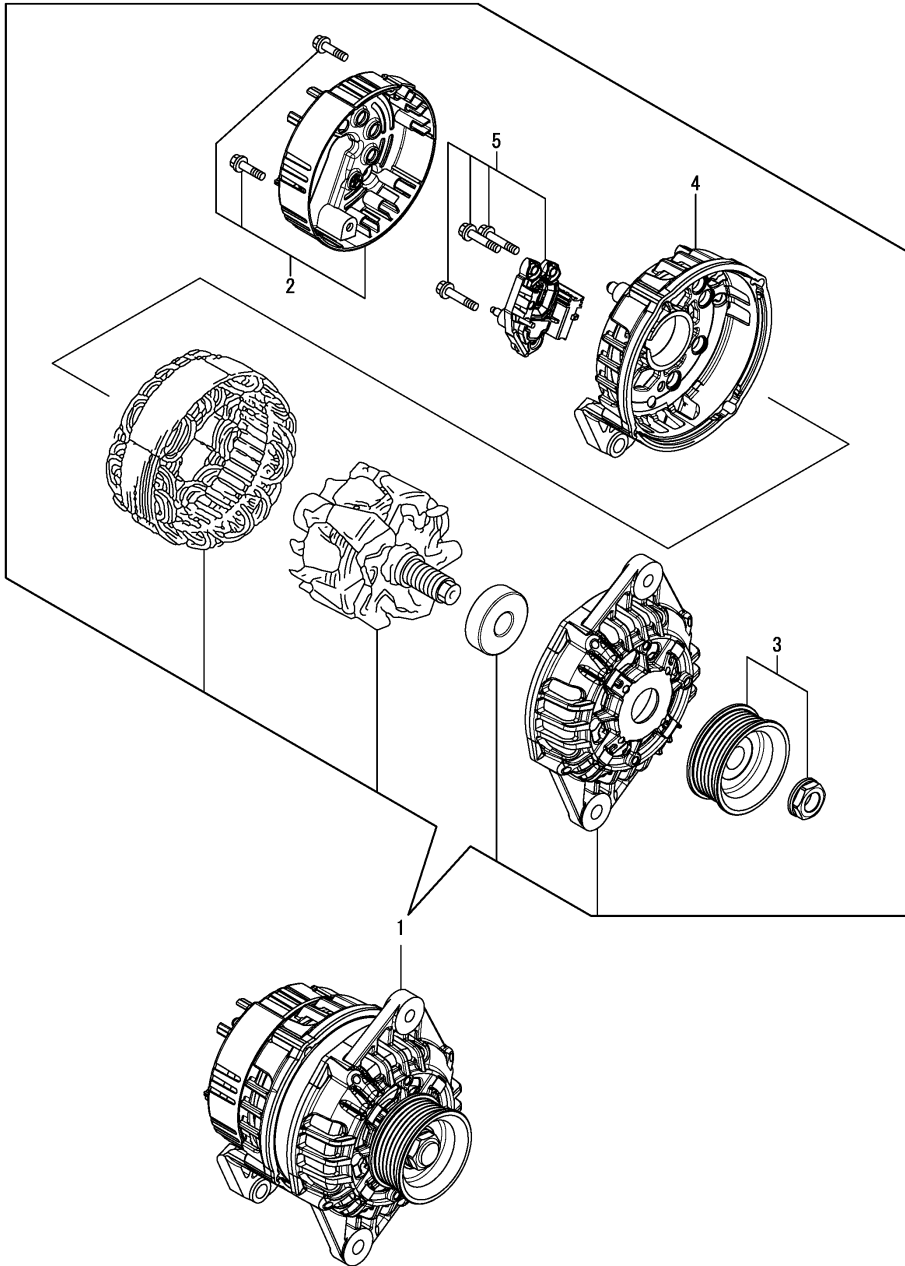

(A)=2YM15
(B)=
(C)=

(D)=
(E)=
(F)=

No.	Lev.	Parts No.	Description	Q'ty						I	R
				(A)	(B)	(C)	(D)	(E)	(F)		
1	1	128990-77250	ALTERNATOR, 12V-125A	1							
2	2	128990-77700	COVER, REAR	1							
3	2	128990-77730	PULLEY	1							
4	2	128990-77770	RECTIFIER, 12V BRACKE	1							
5	2	128990-77780	REGULATOR, 12V SCREW	1							

Fig.32. COVER(V-BELT)

(A)=2YM15
(B)=
(C)=

(D)=
(E)=
(F)=

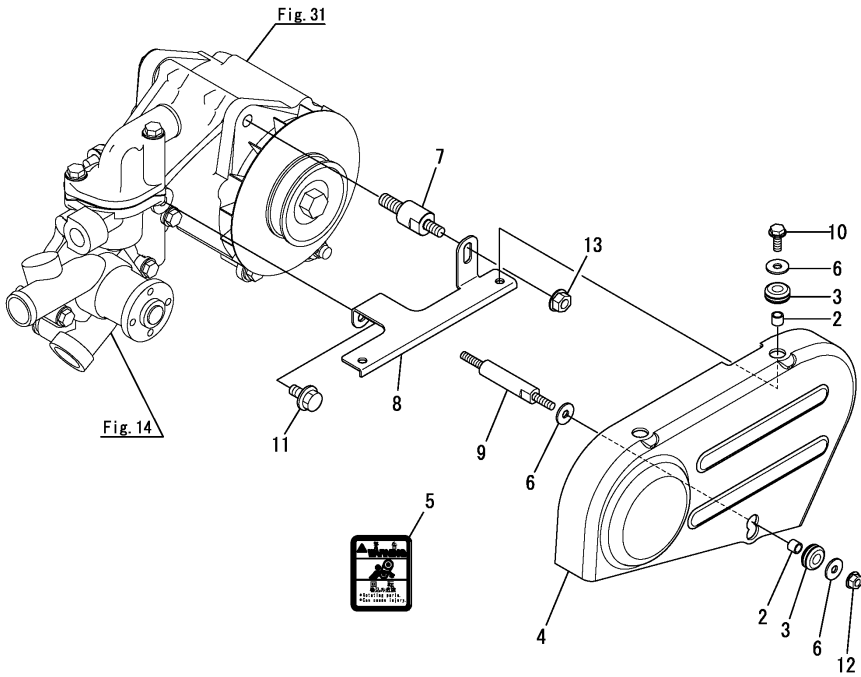
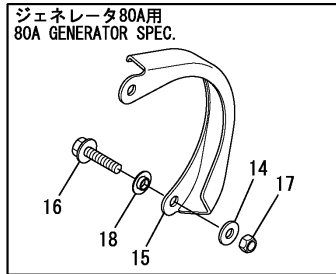

1 inc. 2~5

No.	Lev.	Parts No.	Description	Q'ty						I	R
				(A)	(B)	(C)	(D)	(E)	(F)		
1	1	128990-77460 (A=E/#E7170)	COVER ASSY, BELT	1							W
2	2	128990-77440	COLLAR, BELT COVER	3							
2-1	2	128990-77441 (A=E/#E7170)	COLLAR, M6	3							N
3	2	120270-67120	GROMMET	3							
3-1	2	128990-77600 (A=E/#E7170)	GROMMET, M6	3							R
4	2	128990-77480	COVER, V-BELT	1							
5	2	128377-07350 (A=E/#E7170)	LABEL, CAUTION	1							W
6	1	128990-77510	WASHER, PLAIN	4							
7	1	128990-77410 (A=E/#E5887)	BOLT, BELT COVER	1							Z
8	1	128990-77450	BRACKET, COVER	1							
9	1	128990-77470	BOLT, BELT COVER	1							
10	1	26106-060162	BOLT, M6X 16 PLATED	2							
11	1	26106-080162	BOLT, M8X 16 PLATED	1							
12	1	26366-060002	NUT, M6	1							
13	1	26366-080002	NUT, M8	1							
14	1	128990-77500 (A=E/#E5887)	WASHER, PLAIN	2							Z
15	1	128990-77491 (A=E/#E5887)	COVER, ALTERNATOR	1							Z
16	1	26106-080354 (A=E/#E5887)	BOLT, M8X 35 PLATED	1							Z
17	1	26986-080002 (A=E/#E5887)	NUT, LOCK M8	2							Z
18	1	128990-77540 (A=E/#E5887)	SPACER	2							Z

Fig.33. WIRE HARNESS & RELAY

(A)=2YM15
(B)=
(C)=

(D)=
(E)=
(F)=

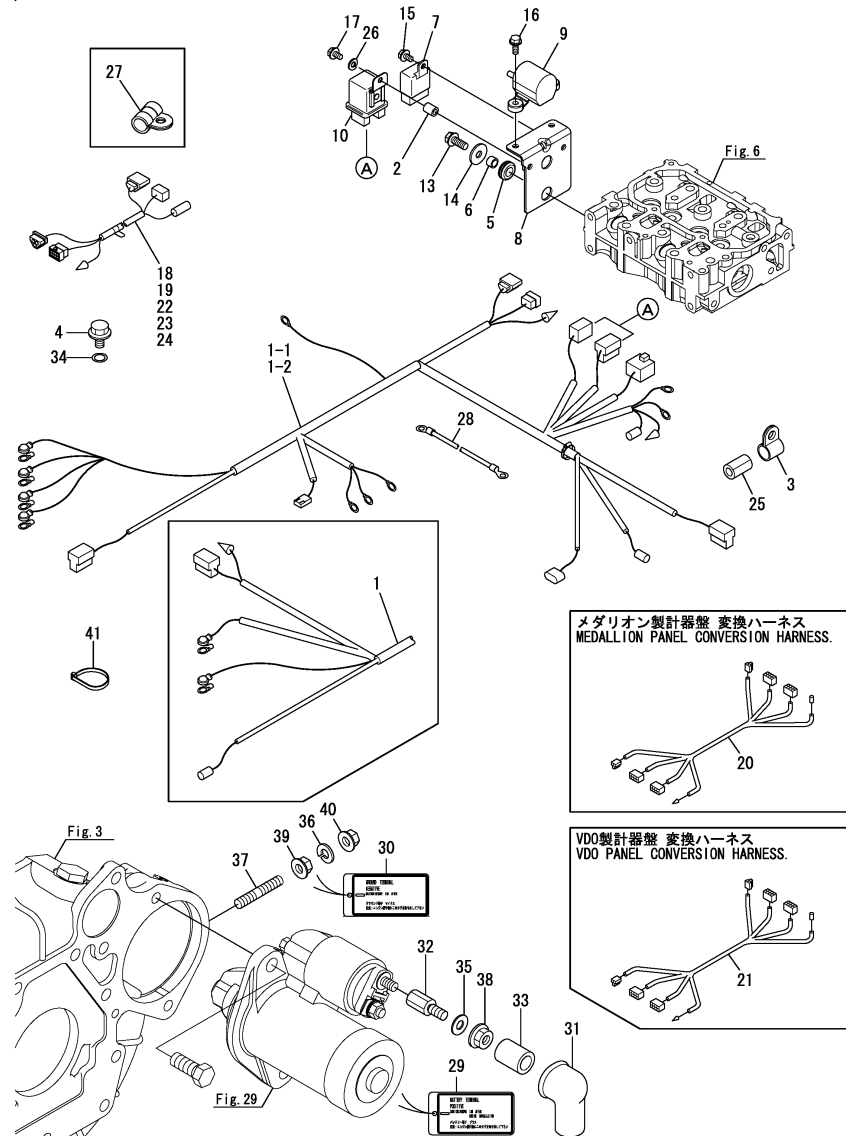

No.	Lev.	Parts No.	Description	Q'ty						I	R
				(A)	(B)	(C)	(D)	(E)	(F)		
1	1	128990-77920	HARNESS, WIRE	1							1
1-1	1	128990-77921	HARNESS, ENGINE	1							S 2
(A=E/#E5888)											
1-2	1	128990-77922	HARNESS, WIRE ENGINE	1							F 5
(A=E/#E7616)											
2	1	128990-42180	COLLAR, BRACKET	1							
3	1	121575-49310	RETAINER, PIPE	1							Z
(A=E/#E5888)											
4	1	26106-080142	BOLT, M8X 14 PLATED	1							
4-1	1	26106-080122	BOLT, M8X 12 PLATED	1							N
(A=E/#E8144)											
5	1	105100-55501	RUBBER, FUEL TANK	2							
5-1	1	128990-77610	GROMMET, M8	2							R
(A=E/#E7170)											
6	1	128990-77430	COLLAR, BRACKET	2							
7	1	119247-77100	RELAY, POWER SN2213	1							
8	1	128890-77400	BRACKET, RELAY	1							
9	1	120270-77511	RELAY, MAGNETIC	1							
9-1	1	128990-77550	RELAY, MAGNET	1							N
(A=E/#E7170)											
10	1	128990-77910	RELAY, GLOW	1							
10-1	1	128990-77911	RELAY, GLOW	1							N
(A=*2010.12.)											
13	1	26106-080202	BOLT, M8X 20 PLATED	2							
14	1	22157-080000	WASHER, 8	2							
15	1	26106-060102	BOLT, M6X 10 PLATED	1							
16	1	26106-060162	BOLT, M6X 16 PLATED	2							
17	1	26106-060252	BOLT, M6X 25 PLATED	1							
18	1	128391-77700	HARNESS, WIRE 3M	1							Z
(A=E/#E5887)											
19	1	128391-77720	HARNESS, WIRE	1							Z
(A=E/#E5887)											
20	1	164100-23900	HARNESS, CONVERSION	1							W 3
(A=E/#E5408)											
20-1	1	164100-23900	HARNESS, CONVERSION	1							Z 3
(A=E/#E5887)											
21	1	164100-23910	HARNESS, CONVERSION	1							W 4
(A=E/#E5888)											
22	1	164100-22820	HARNESS, EXT 4M	1							W
(A=E/#E5888)											
23	1	164100-22830	HARNESS, EXT 6M	1							W
(A=E/#E5888)											
24	1	164100-22840	HARNESS, EXT 10M	1							W
(A=E/#E5888)											
25	1	124770-77940	PROTECTOR, HARNESS	1							
25-1	1	129670-77940	PROTECTOR	1							R
(A=*2007.11.)											
25-2	1	129670-77940	PROTECTOR	1							Z
(A=E/#E5888)											
26	1	22217-060000	WASHER, SPRING 6	1							
27	1	129672-49050	RETAINER, PIPE	1							W

Remarks

* Refer to Fig.39 for the combination of generator, wire harness, and panel.

- (1)It is made by YAZAKI.
- (2)It is made by DEUTSCH : VALEO generator specification.
- (3)For MEDALLION
- (4)For VDO : VALEO generator specification.
- (5)No.1-2 & 28 interchangeable by set.

Fig.33. WIRE HARNESS & RELAY

(A)=2YM15
(B)=
(C)=

(D)=
(E)=
(F)=

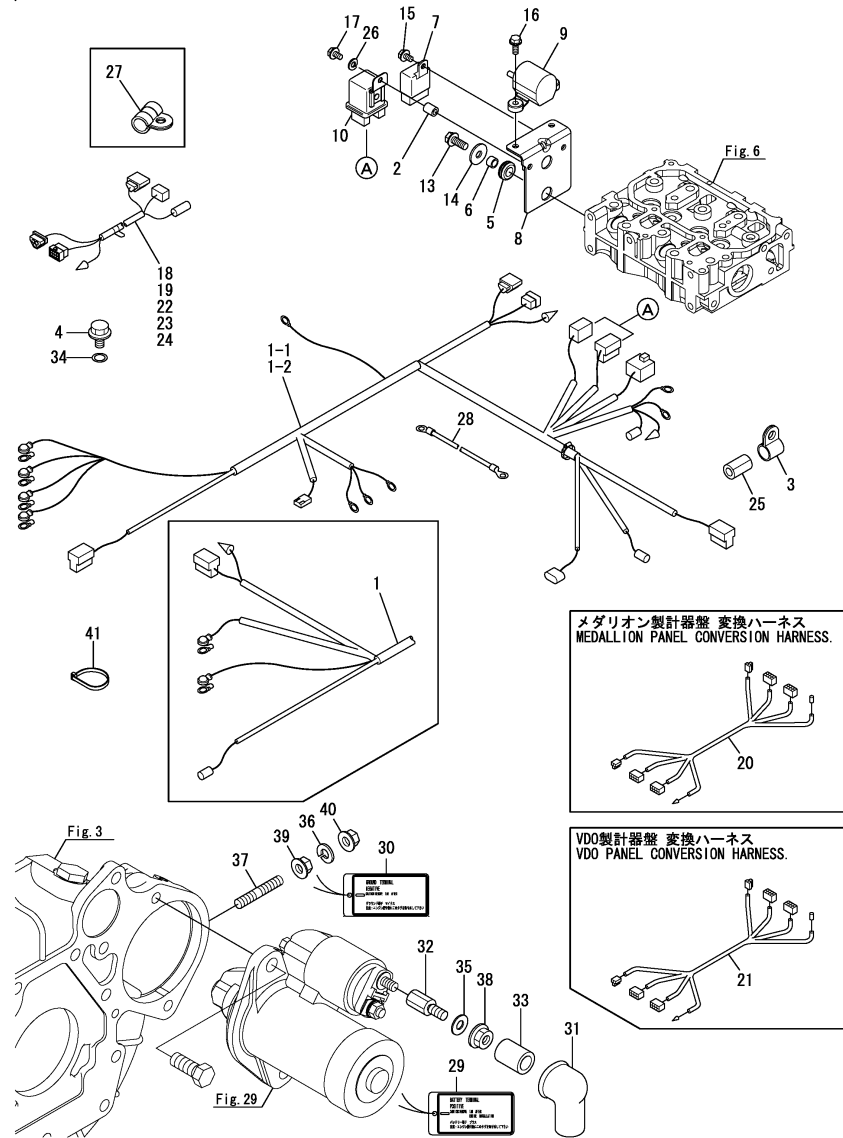

No.	Lev.	Parts No.	Description	Q'ty						I	R
				(A)	(B)	(C)	(D)	(E)	(F)		
28	1	128990-77940 (A=#E5888) (A=#E7616)	HARNESS,ALT-STARTER	1						W	5
29	1	129677-07450 (A=#E8144)	LABEL, BATTERY+	1						W	
30	1	129677-07460 (A=#E8144)	LABEL, GROUND-	1						W	
31	1	129670-77030 (A=#E8144)	COVER, TERMINAL B	1						W	
32	1	119175-77500 (A=#E8144)	BOLT, SPACER	1						W	
33	1	128991-77800 (A=#E8144)	COVER	1						W	
34	1	22190-080002 (A=#E8144)	WASHER, SEAL 8	1						W	
35	1	22217-080000 (A=#E8144)	WASHER, SPRING 8	1						W	
36	1	22217-080000 (A=#E8144)	WASHER, SPRING 8	1						W	
37	1	26216-080302 (A=#E8144)	STUD, M8X 30	1						W	
38	1	26366-080002 (A=#E8144)	NUT, M8	1						W	
39	1	26366-080002 (A=#E8144)	NUT, M8	1						W	
40	1	26366-080002 (A=#E8144)	NUT, M8	1						W	
41	1	29621-200001 (A=*2017.11.)	BAND, TR200	3						W	

Remarks

* Refer to Fig.39 for the combination of generator, wire harness, and panel.

- (1)It is made by YAZAKI.
- (2)It is made by DEUTSCH : VALEO generator specification.
- (3)For MEDALLION
- (4)For VDO : VALEO generator specification.
- (5)No.1-2 & 28 interchangeable by set.

Fig.43. (33A)WIRE HARNESS (2-PANEL SPEC.)

(A)=2YM15
(B)=
(C)=

(D)=
(E)=
(F)=

No.	Lev.	Parts No.	Description	Q'ty						I	R
				(A)	(B)	(C)	(D)	(E)	(F)		
1	1	164100-23700 (A=E/#E7170)	HARNESS, DUAL PANEL	1							W
2	1	119773-91850	RELAY, DC12V	1							

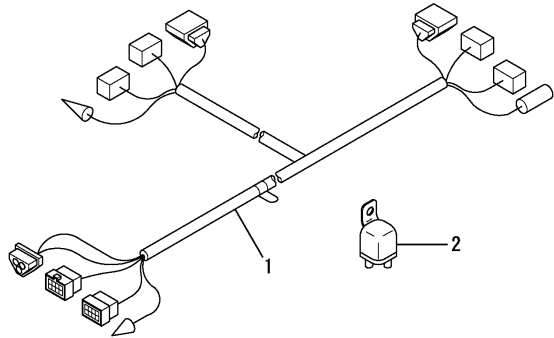
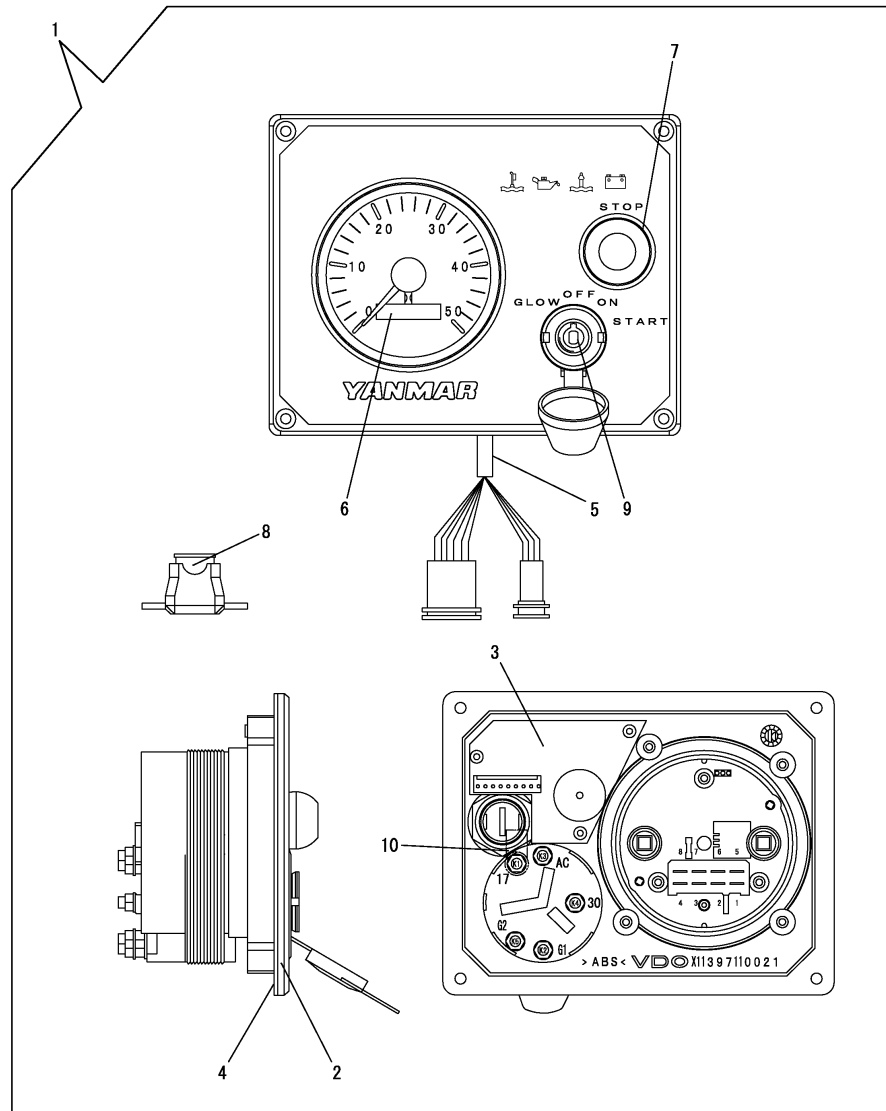

Fig.34. INSTRUMENT PANEL(B-TYPE)(OPTIONAL)

(A)=2YM15
(B)=
(C)=

(D)=
(E)=
(F)=



No.	Lev.	Parts No.	Description	Q'ty						I	R
				(A)	(B)	(C)	(D)	(E)	(F)		
1	1	129271-91110	PANEL, INSTRUMENT B	1							
1-1	1	129271-91111	PANEL, INSTRUMENT B	1							N
(A=*2005.12.)											
1-2	1	129271-91112	PANEL	1							N
(A=*2008.09.)											
1-3	1	129271-91113	PANEL, INSTRUMENT B	1							N
(A=*2009.09.)											
2	2	129271-91120	STICKER	1							
3	2	129271-91130	CIRCUIT	1							
3-1	2	129271-91131	CIRCUIT WITH LED&BZR	1							N
(A=*2008.09.)											
3-2	2	129271-91132	CIRCUIT, PANEL B	1							N
(A=*2009.09.)											
4	2	129271-91140	SEAL, RUBBER	1							
5	2	129271-91150	HARNESS, WIRE	1							
6	2	129271-91210	TACHOMETER	1							
6-1	2	129271-91211	TACHOMETER, AN 10.29	1							N
(A=*2009.09.)											
7	2	129271-91220	SWITCH, STOP	1							
8	2	129271-91230	FUSE, PANEL	1							
9	2	127412-91250	SWITCH, KEY	1							
10	2	129271-91260	CAP, RUBBER M5	1							W
(A=*2005.12.)											

Remarks

* This item is applicable to [(A)=Dec., 2011] or previous machines(Refer to Fig.38).

* Refer to Fig.39 for the combination of generator, wire harness, and panel.

Fig.35. TOOL

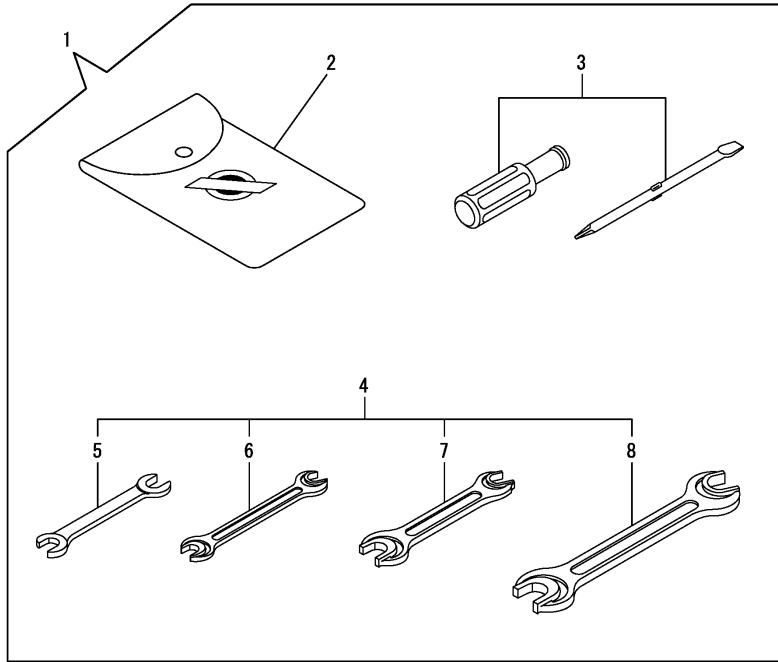

(A)=2YM15
(B)=
(C)=

(D)=
(E)=
(F)=

No.	Lev.	Parts No.	Description	Q'ty						I	R
				(A)	(B)	(C)	(D)	(E)	(F)		
1	1	129270-92100	TOOL ASSY	1							
2	2	129270-92600	BAG, TOOL	1							
3	2	129270-92650	DRIVER	1							
4	2	129270-92690	WRENCH ASSY	1							
5	3	129270-92610	WRENCH, 10X13	1							
6	3	129270-92620	WRENCH, 12X14	1							
7	3	129270-92630	WRENCH, 17X19	1							
8	3	129270-92640	WRENCH, 22X24	1							

Fig.36. GASKET SET(OPTIONAL)

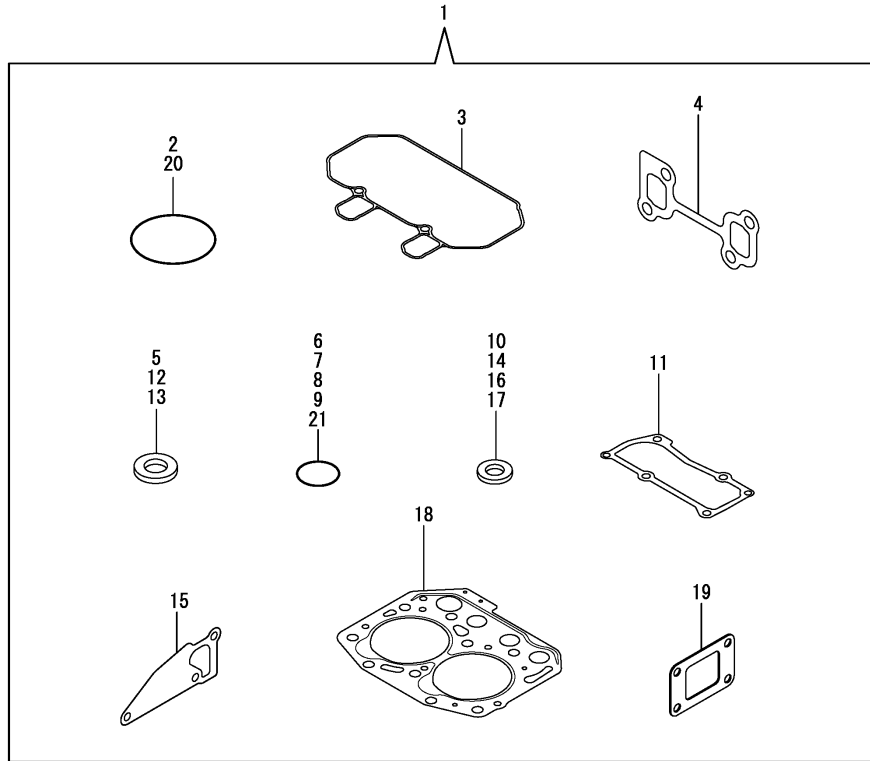

No.	Lev.	Parts No.	Description	Q'ty						I	R
				(A)	(B)	(C)	(D)	(E)	(F)		
1	1	728790-92600	GASKET SET	1							
2	2	121850-51960	O-RING, FUEL PUMP	1							
3	2	119415-11310	GASKET, BONNET	1							
4	2	119415-13110	GASKET, MANIFOLD	1							
5	2	22190-080002	WASHER, SEAL 8	6							
6	2	24311-000320	O-RING, 1AP32.0	2							
7	2	119717-32060	O-RING, P15.0	1							
8	2	119624-32040	O-RING, P12.0	1							
9	2	119717-32050	O-RING, P17.0	3							
10	2	119600-11460	GASKET, NOZZLE	4							
11	2	119415-11330	GASKET, BONNET COVER	1							
12	2	22190-160002	WASHER, SEAL 16	2							
13	2	22190-120002	WASHER, SEAL 12	8							
14	2	129901-59560	GASKET, FUEL RETURN	2							
15	2	119515-42020	GASKET, WATER PUMP	1							
16	2	23414-080000	GASKET, 8X1.0	1							
17	2	124465-44950	GASKET, 16	2							
18	2	119415-01330	GASKET, HEAD	1							
19	2	128370-13201	GASKET, ELBOW A	1							
20	2	24327-000600	O-RING, 4EG60.0	1							
21	2	24357-240230	O-RING, 4E24023	1							

Fig.38. INSTRUMENT PANEL(MEDALLION)(FROM JAN. 2012)

1, 1-2, 1-5 inc.2 to 15.

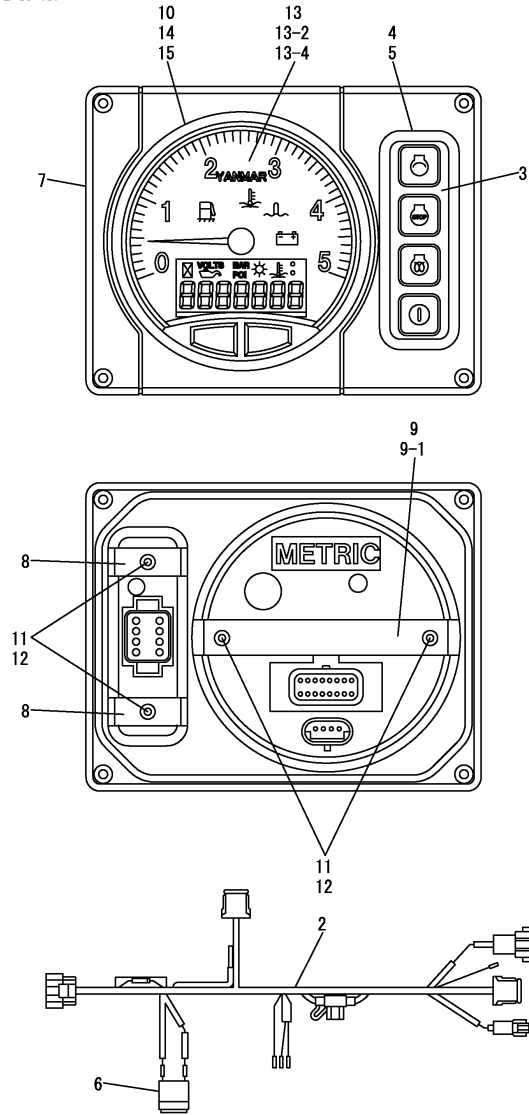

(A)=2YM15
(B)=
(C)=

(D)=
(E)=
(F)=

No.	Lev.	Parts No.	Description	Q'ty						I	R
				(A)	(B)	(C)	(D)	(E)	(F)		
1	1	164100-30100 (A=*2012.01.)	PANEL ASSY, B20	1							W
1-1	1	164100-30101 (A=*2012.06.)	PANEL ASSY, B20	1							N
1-2	1	164100-30102 (A=E/#E5888)	PANEL ASSY, B20 MD	1							S 1
1-3	1	164100-30103 (A=E/#E6816)	PANEL ASSY, B20 MD	1							N
1-4	1	164100-30104 (A=E/#E7448)	PANEL ASSY, B20 MD	1							N
1-5	1	164100-30105 (A=EE08848)	PANEL ASSY, B20 MD	1							S 2
2	2	164100-21100	HARNESS, PANEL	1							
3	2	164100-31100	SWITCH, PANEL	1							
3-1	2	164100-31101 (A=*2012.06.)	SWITCH, PANEL MD	1							N
3-2	2	164100-31102 (A=E/#E7448)	SWITCH, PANEL MD	1							N
4	2	164100-31150	GASKET, SWITCH MD	1							
5	2	164100-31900	BEZEL, SWITCH BK MD	1							
6	2	164100-36100	BUZZER, PANEL	1							
7	2	164100-39100	FRAME, PANEL B	1							
8	2	164100-39120	BRACKET, SWITCH MD	2							
9	2	164100-39130	BRACKET, GAUGE 5	1							
9-1	2	164100-39131 (A=E/#E5888)	BRACKET, GAUGE 5 MD	1							S 1
10	2	164100-39150	CAP, GAUGE TERMINAL	1							
11	2	164100-39180	WASHER, LOCK MD	4							
12	2	164100-39190	NUT, M3.5 MD	4							
13	2	164100-53100	GAUGE, TACHOMETER	1							
13-1	2	164100-53101 (A=*2012.06.)	GAUGE, TACH LCD 5 MD	1							N
13-2	2	164100-53102 (A=E/#E5888)	GAUGE, TACH LCD 5 MD	1							S 1
13-3	2	164100-53103 (A=E/#E6816)	GAUGE, TACHOMETER	1							N
13-4	2	164100-53104 (A=EE08848)	GAUGE, TACH LCD 5 MD	1							S
14	2	164100-53150	GASKET, GAUGE 5 MD	1							
15	2	164100-53900	BEZEL, GAUGE 5 BK MD	1							

Remarks

* This item is applicable to [(A)=Jan., 2012] or following machines(Refer to Fig.34).

* Refer to Fig.39 for the combination of generator, wire harness, and panel.

(1)Valeo generator specification.

(2)No.1-5 is interchangeable with a set of Fig.10 No.11-1, Fig.14 No.47-2 & Fig.37 No.1-1.

Fig.39. COMBINATION OF GENERATOR, WIRE HARNESS, AND PANEL

(A)=2YM15
(B)=
(C)=

(D)=
(E)=
(F)=

No.	Lev.	Parts No.	Description	Q'ty						I	R
				(A)	(B)	(C)	(D)	(E)	(F)		
1	1	128271-77200	GENERATOR, 12V-60A	1							
2	1	119573-77201	ALTERNATOR, 12V-80A	1							
3	1	128990-77250	ALTERNATOR, 12V-125A	1							
10	1	128990-77920	HARNESS, WIRE	1							
11	1	128990-77921	HARNESS, ENGINE	1							
20	1	128391-77700	HARNESS, WIRE 3M	1							
21	1	128391-77720	HARNESS, WIRE	1							
22	1	164100-22820	HARNESS, EXT 4M	1							
23	1	164100-22830	HARNESS, EXT 6M	1							
30	1	164100-23900	HARNESS, CONVERSION	1							
40	1	129271-91113	PANEL, INSTRUMENT B	1							
41	1	129271-91302	PANEL, KEYLESS B	1							
42	1	164100-30101	PANEL ASSY, B20	1							
43	1	164100-30102	PANEL ASSY, B20 MD	1							

見出番号 Ref. No.	ジェネレータ(オルタネータ) GENERATOR(ALTERNATOR)			エンジンハーネス ENGINE WIRE HARNESS		延長ハーネス EXT. WIRE HARNESS				変換ハーネス CONV. WIRE HARNESS	パネル PANEL				
	No.1	No.2	No.3	No.10	No.11	No.20	No.21	No.22	No.23	No.30	No.40	No.41	No.42	No.43	
部品番号 PARTS NUMBER	128271-77200	119573-77201	128990-77250	128990-77920	128990-77921	128391-77700	128391-77720	164100-22820	164100-22830	164100-23900	129271-91113	129271-91302	164100-30101	164100-30102	
仕様 SPECIFICATION	12V-60A	12V-80A	12V-120A	—	—	3m	6m	4m	6m	—	B	B キーレス B KEYLESS	B20	B20	
メーカー MAKER	HITACHI	HITACHI	VALEO	—	—	—	—	—	—	—	VDO	VDO	MEDALLION	MEDALLION	
コネクタメーカー CONNECTORS MAKER	(YAZAKI)	(YAZAKI)	(YAZAKI)	ALTERNATOR: YAZAKI PANEL SIDE: YAZAKI	ALTERNATOR: YAZAKI PANEL SIDE: AMPHENOL	YAZAKI	YAZAKI	AMPHENOL	AMPHENOL	ENG SIDE: YAZAKI PANEL SIDE: AMPHENOL	YAZAKI	YAZAKI	AMPHENOL	AMPHENOL	
生産年 PRODUCTION YEAR	2004	●	○	●		○	○				○				
	2005	●	○	●		○	○				○				
	2006	●	○	●		○	○				○				
	2007	●	○	●		○	○				○	○			
	2008	●	○	●		○	○				○	○			
	2009	●	○	●		○	○				○	○			
	2010	●	○	●		○	○				○	○			
	2011	●	○	●		○	○				○	○			
	2012	●	○	●		○	○			●			○	(○)※1	
	2013	●	○	●		○	○			●			○	(○)※1	
2014			●		●			○	○					○	

● : 標準 STANDARD , ○ : オプション OPTION

※1 : オルタネータ回転数信号に対するパルス値の設定を変更する必要があります。

※1 : It is necessary to change a setup of the pulse value over an alternator number-of-rotations signal.

Fig.45. PROPELLER NUT

(A)=2YM15
(B)=
(C)=

(D)=
(E)=
(F)=

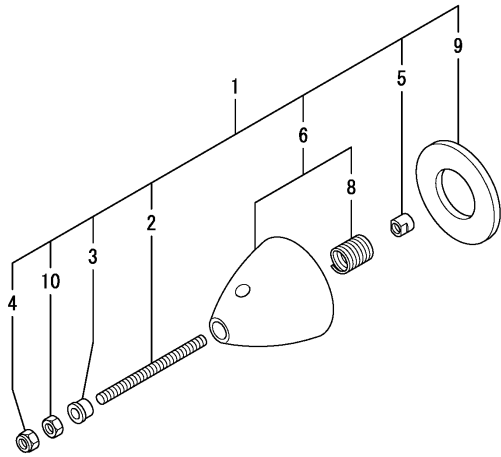

No.	Lev.	Parts No.	Description	Q'ty						I	R
				(A)	(B)	(C)	(D)	(E)	(F)		
1	1	796420-09200 (A=E/#E7170)	NUT ASSY, PROPELLER	1							W
2	2	196440-09150	BOLT, M8X105	1							
2-1	2	196440-09151 (A=E/#E8373)	BOLT, M8X115	1							R
3	2	196440-09160	SPACER	1							
4	2	196440-09170	NUT, NYLON	1							
5	2	196440-09180	NUT, M8	1							
6	2	196420-09200	NUT ASSY, PROPELLER	1							
8	3	26273-160151	INSERT, 16X1.5D	1							
9	2	196420-09220	WASHER, PROPELLER	1							
10	2	26793-080002	NUT, LOCK M8	1							

Parts No. Index

Parts No.	Fig. No.	Ref. No.
101304-59020	22	33
101720-55750	23	8
103854-39140	22	31
104214-13580	8	10
		22
104214-83980	28	13
104264-59020	23	15
104500-55710	23	5
104511-78780	13	25
105010-11490	6	5
105100-55501	33	5
105311-01090	1	5
105430-55041	24	8
105583-85900	28	12
110250-55610	23	4
114250-39450	12	13
118200-53010	22	2
118400-51370	19	48
119025-51520	19	65 -1
119125-51370	19	48 -1
119125-51900	19	87 -1
119129-77250	31	14
119129-77260	31	15
119129-77320	31	3
119129-77890	31	20
119129-77900	31	21
119129-77930	31	19
119175-77500	33	32
119247-77100	33	7
119285-01990	1	8
119285-11990	6	14
119285-66650	20	139
119305-35151	12	1
119305-35170	12	1 -1
119305-59120	22	4
119309-01810	11	7
119415-01330	1	30
	36	18
119415-01720	3	5
119415-11200	6	24
119415-11240	6	25
119415-11310	6	48
	36	3
119415-11320	6	49
119415-11330	6	50
	36	11
119415-11380	6	38
119415-11750	6	6
119415-13110	15	1
	36	4

Parts No.	Fig. No.	Ref. No.
119415-14580	9	3
119415-14581	9	3 -1
119415-21700	10	1
119415-39210	12	14
119415-39211	12	14 -1
119415-51030	19	5
119415-51100	19	9
119415-51400	19	49
119415-51500	19	64
119415-51700	19	74
119415-51710	19	75
119415-51750	19	76
119415-51760	19	77
119415-59540	22	13
119415-59810	22	9
119415-59820	22	10
119515-01200	1	29
119515-11100	6	16
119515-11101	6	16 -1
119515-11110	6	17
119515-11280	6	29
119515-11800	6	12
119515-14400	9	2
119515-22080	10	14
119515-22300	10	20
119515-22500	10	16
119515-22550	10	31
119515-22900	10	29
119515-23000	10	22
119515-23001	10	22 -1
119515-23600	10	27
119515-23601	10	27 -1
119515-23610	10	35
119515-23611	10	35 -1
119515-42020	14	13
	36	15
119515-42041	14	3
119515-53001	22	1
119515-53010	22	3
119515-61440	20	20
119527-61700	20	129
119540-42000	14	1
119573-77201	31	1
	39	2
119600-11460	6	4
	36	10
119620-01750	3	11
119620-01800	2	8
119620-02020	1	9
119620-14200	9	1

Parts No.	Fig. No.	Ref. No.
119620-21941	10	13
119620-49290	14	29
119620-59700	22	24
119621-21680	10	12
119621-21681	10	12 -1
119623-01250	1	6
119624-32040	2	19
	36	8
119660-01911	2	18
119660-61300	20	76
119660-61901	20	65
119717-01501	2	1
119717-01521	2	6
119717-01570	2	3
119717-01590	2	4
119717-01750	2	31
119717-02410	1	12
119717-02411	1	12 -1
119717-02930	1	26
119717-03031	6	39
119717-03070	6	40
		41
119717-11131	6	18
119717-11190	6	20
119717-11260	6	28
119717-11340	6	21
119717-11350	6	22
119717-11650	6	30
119717-23200	10	26
119717-23910	10	25
119717-25050	9	9
119717-25100	9	10
119717-25101	9	10 -1
119717-25930	9	15
119717-32050	2	20
	36	9
119717-32060	12	10
	36	7
119717-32080	2	11
119717-32100	2	10
119717-32110	2	15
119717-32120	2	16
119717-42031	14	4
119717-42320	14	11
119717-51060	19	6
119717-51070	19	7
119717-51150	19	92
119717-51180	19	14
119717-51190	19	15
119717-51200	19	16

Parts No.	Fig. No.	Ref. No.
119717-51201	19	16 -1
119717-51300	19	43
119717-51330	19	46
119717-51420	19	51
119717-51480	19	90
119717-51481	19	90 -1
119717-51490	19	91
119717-51491	19	91 -1
119717-51570	19	14 -1
119717-51860	19	89 -1
119717-51930	20	68 -1
119717-61050	20	2
119717-61060	20	3
119717-61070	20	4
119717-61100	20	5
119717-61120	20	8
119717-61130	20	9
119717-61140	20	10
119717-61150	20	10 A
119717-61200	20	72
119717-61201	20	72 -1
119717-61400	20	13
119717-61500	20	29
119717-77800	6	57
119717-77801	6	57 -1
119740-42350	14	26
119740-61470	20	87 -1
119773-59511	22	20
119773-91850	43	2
119802-03100	6	42
119802-03110	6	43
119802-03121	6	44
119802-03131	6	45
119802-03141	6	46
119802-32130	2	17
119810-02940	1	31
119810-02941	1	31 -1
119813-59950	22	25
119840-59570	22	12
119C10-42000	14	1 -1
119C10-42320	14	11 -1
120270-67120	32	3
120270-77511	33	9
121111-21501	10	7
121120-01620	3	10
121370-55601	23	3
121370-55730	23	7
121450-42450	14	23
121574-86320	25	14
	27	2

Parts No. Index

Parts No.	Fig. No.	Ref. No.
121575-49310	16	8
	33	3
121575-66830	20	21 -1
121750-59890	23	21
121750-59910	46	17
121850-51960	2	21
	36	2
122710-51090	19	8
123310-77640	29	26
123325-35140	46	12
123325-35160	46	2
123325-35170	46	3
123672-55760	46	6
123678-55890	46	10
123682-07852	5	5 A
123900-77700	30	2
123900-77730	30	5
124060-01050	1	4
124070-13300	8	7
		19
124070-13520	8	6
124070-42400	13	22
	41	22
124080-77390	31	10
124080-77520	31	12
124085-02220	3	12
124101-49530	14	17
124160-01751	2	29
	6	37
124160-01910	1	7
124195-77770	29	23
124223-49050	16	11
124465-44950	14	21
		22
		32
		38
	36	17
124550-51350	19	47
124550-77030	29	25
124770-77940	33	25
124772-08341	4	8 -2
		9 -2
124950-21600	10	10
127412-91250	34	9
128170-13600	8	3
128170-86501	25	12
128171-81510	26	2
128171-81520	26	1
128171-81530	26	3
128270-08341	4	7 -2

Parts No.	Fig. No.	Ref. No.
128270-12540	7	5
128271-77200	30	1
	39	1
128271-77720	30	4
128271-77740	30	6
128271-77750	30	7
128275-39710	12	19
128296-07190	5	6
128296-07400	5	7
128296-07420	5	8
128296-07450	5	9
128296-07460	5	10
128370-13201	8	1
		16
		28
	36	19
128370-13600	8	5
128370-13601	8	5 -1
128370-13610	8	11
128377-07150	5	3
128377-07350	5	5 C
	32	5
128377-08120	4	3
128377-08130	4	4
128377-08340	4	7
128377-08341	4	7 -1
128377-08350	4	8
		9
128377-08351	4	8 -1
		9 -1
128391-77700	33	18
	39	20
128391-77720	33	19
	39	21
128397-13530	8	2
128397-44500	15	21
128397-44510	15	23
128790-01700	3	2
128790-08120	4	1
128790-08130	4	2
128790-08150	4	1 -1
128790-12210	7	1
128790-12500	7	2
128790-21590	10	8
128790-21670	10	11 -1
128790-35080	12	11
128790-35450	12	2
128790-35460	12	6
128790-42350	14	47 -2
128790-44400	15	19

Parts No.	Fig. No.	Ref. No.
128790-44900	15	2
128790-49050	16	4
128790-49051	16	4 -1
128790-67150	25	1
128790-77580	37	1
128790-77600	37	1 -1
128790-77820	6	58
128890-13530	8	2 -1
128890-13590	8	6 A
128890-13591	8	6 -1
		6 A-1
128890-13600	8	5 A
128890-13601	8	5 A-1
128890-49300	8	35
128890-55020	14	36
		36 -1
		45
128890-59040	22	22
128890-59041	22	22 -1
128890-59050	23	16
128890-59051	23	16 -1
128890-59060	23	17
128890-59061	23	17 -1
128890-77310	30	9
	31	24
	37	2
128890-77400	33	8
128990-01650	3	9
128990-07270	5	2
128990-07900	5	1
128990-07910	6	1
128990-13510	8	17
128990-13520	8	18
128990-13610	8	23
128990-21650	10	11
128990-21670	10	39
128990-21671	10	39 -1
		39 -2
128990-34850	11	1
128990-34860	11	2
128990-34900	5	5 B
128990-42151	13	21
128990-42160	13	23
128990-42170	13	24
128990-42180	33	2
128990-42260	14	25
128990-42350	14	47
128990-42351	14	47 -1
128990-42500	13	1
128990-42510	13	1 -1

Parts No.	Fig. No.	Ref. No.
128990-42510	13	1 -2
128990-42520	13	20
	41	20
128990-42550	13	3
	41	3
128990-42560	13	8
	41	8
128990-42570	13	17
	41	17
128990-44070	15	10
128990-44071	15	10 -1
128990-44080	15	11
128990-44081	15	11 -1
128990-44090	15	14
128990-44100	15	15
128990-44110	15	16
128990-44120	15	17
128990-44401	15	19 -1
128990-44500	14	24 -1
128990-49010	16	1
128990-49011	16	1 -1
128990-49020	16	3
128990-49021	16	3 -1
128990-49030	3	18
128990-49040	8	12
128990-49060	16	6
128990-49090	8	24
128990-49110	16	2
		5
128990-49120	8	31
128990-49130	8	32
128990-49140	8	33
128990-49150	16	7
128990-49161	16	17
		17 -1
128990-49170	16	18
		18 -1
128990-49190	16	20
128990-49320	14	33
		39
128990-49330	14	34
128990-49331	14	49
		49 -1
128990-49340	14	50
		50 -1
128990-49350	14	40
128990-49351	14	40 -1
128990-49360	14	41
128990-49370	14	42
128990-49380	14	43

Parts No. Index

Parts No.	Fig. No.	Ref. No.
128990-49390	14	44
128990-49391	14	44 -1
128990-49392	14	44 -2
128990-49400	14	43 -1
128990-49800	14	18
128990-55010	23	1
128990-55011	23	1 -1
128990-59130	24	2
128990-59131	24	2 -1
128990-59150	23	11
128990-59510	22	20 -1
128990-59530	23	12
128990-59700	24	1
128990-59890	16	22
	23	21 -1
128990-59900	23	22
128990-61560	20	96
128990-77250	37	18
	39	3
	42	1
128990-77320	37	3
128990-77330	30	10
	31	25
128990-77341	37	4
128990-77350	41	30 -1
128990-77410	32	7
	37	5
128990-77430	33	6
128990-77440	32	2
128990-77441	32	2 -1
128990-77450	32	8
128990-77460	32	1
128990-77470	32	9
128990-77480	32	4
128990-77491	32	15
128990-77500	32	14
128990-77510	32	6
128990-77540	32	18
128990-77550	33	9 -1
128990-77600	32	3 -1
128990-77610	33	5 -1
128990-77700	42	2
128990-77730	42	3
128990-77770	42	4
128990-77780	42	5
128990-77910	33	10
128990-77911	33	10 -1
128990-77920	33	1
	39	10
128990-77921	33	1 -1

Parts No.	Fig. No.	Ref. No.
128990-77921	39	11
128990-77922	33	1 -2
128990-77940	33	28
128990-81150	3	19
128990-86301	27	1
128990-86310	27	1 -1
128990-86350	27	7
128991-77800	33	33
128995-42150	41	21
128995-42170	41	29
128995-42500	41	1
129001-32320	2	13
129001-32330	2	14
129005-59830	12	15
129008-61301	20	76 -1
129051-49310	14	39 -1
		39 -2
		39 -3
129052-61390	20	12
129065-55760	46	7
129065-55770	46	8
129065-55800	46	9
129100-01580	3	8
	10	2
129100-35140	12	3
129100-51570	19	70
129100-61650	20	59
129150-11230	6	31
129150-11750	6	33
129150-25301	9	14
129150-59131	22	7
129155-51020	19	4
129155-51140	19	12
129155-51280	19	41
		42
	20	6
129155-51450	19	59
129155-51521	19	65
129155-51530	19	66
129155-51540	19	67
129155-51550	19	68
129155-51580	19	72
129155-51591	19	73
129155-51600	19	20
129155-52051	21	2
129155-61341	20	77
129155-61450	20	21
129155-61460	20	78
129155-61461	20	78 -1
129155-61480	20	23

Parts No.	Fig. No.	Ref. No.
129156-51910	19	79
129156-61460	20	22
129158-52000	19	97
	21	1
129158-52101	21	3
129209-61370	20	11
129209-61920	20	86 -1
129209-61930	20	130
129209-61940	20	134
129209-61960	20	136
129209-61961	20	136 -1
129209-61970	20	131
129270-44500	15	22
129270-44501	15	22 -1
129270-92100	35	1
129270-92600	35	2
129270-92610	35	5
129270-92620	35	6
129270-92630	35	7
129270-92640	35	8
129270-92650	35	3
129270-92690	35	4
129271-77641	37	6
129271-77950	20	132
129271-91110	34	1
129271-91111	34	1 -1
129271-91112	34	1 -2
129271-91113	34	1 -3
	39	40
129271-91120	34	2
129271-91130	34	3
129271-91131	34	3 -1
129271-91132	34	3 -2
129271-91140	34	4
129271-91150	34	5
129271-91210	34	6
129271-91211	34	6 -1
129271-91220	34	7
129271-91230	34	8
129271-91260	34	10
129271-91302	39	41
129470-67200	25	2
129486-61540	20	49
129495-55610	46	4
129495-55620	46	5
129508-11180	6	19
129608-77010	29	1
129608-77110	29	4
129612-42290	30	8
	31	23

Parts No.	Fig. No.	Ref. No.
129612-77710	30	3
129670-13600	8	3 -1
129670-44570	15	24
129670-49500	16	10 -1
129670-55750	46	1
129670-55810	46	16
129670-77030	29	25 -1
		25 -2
	33	31
129670-77940	33	25 -1
		25 -2
129672-49050	33	27
129673-44110	15	7
129673-44130	15	18
129673-44131	15	18 -1
129673-44150	15	9
129677-07450	33	29
129677-07460	33	30
129677-49950	7	8
	8	29
		30
		30 -1
	16	21
129677-86500	25	17
129698-77020	29	2
129698-77101	29	3
129698-77120	29	5
129698-77130	29	7
129698-77140	29	6
129698-77150	29	8
129698-77161	29	9
129698-77170	29	10
129698-77180	29	17
129698-77190	29	18
129698-77200	29	19
129698-77210	29	20
129698-77220	29	21
129698-77230	29	22
129698-77240	29	15
129698-77250	29	16
129698-77260	29	11
129698-77270	29	13
129698-77280	29	14
129795-08340	4	11
129900-32130	2	12
129901-11450	6	3
129901-53800	22	3 A
129901-59560	22	19
	36	14
129916-49740	14	12

Parts No. Index

Parts No.	Fig. No.	Ref. No.
138603-59380	24	4
158552-61700	20	60
158552-61710	20	64
158552-61900	20	81 -1
158600-51170	19	13
158600-51270	19	40
158600-51410	19	50
158600-51420	19	52
158600-51441	19	53
158600-51442	19	53 -1
158600-51570	19	71
158600-51790	19	78
158601-61710	20	88 -1
158601-61760	20	88
164100-21100	38	2
164100-22820	33	22
	39	22
164100-22830	33	23
	39	23
164100-22840	33	24
164100-23700	43	1
164100-23900	33	20
		20 -1
	39	30
164100-23910	33	21
164100-30100	38	1
164100-30101	38	1 -1
	39	42
164100-30102	38	1 -2
	39	43
164100-30103	38	1 -3
164100-30104	38	1 -4
164100-30105	38	1 -5
164100-31100	38	3
164100-31101	38	3 -1
164100-31102	38	3 -2
164100-31150	38	4
164100-31900	38	5
164100-36100	38	6
164100-39100	38	7
164100-39120	38	8
164100-39130	38	9
164100-39131	38	9 -1
164100-39150	38	10
164100-39180	38	11
164100-39190	38	12
164100-53100	38	13
164100-53101	38	13 -1
164100-53102	38	13 -2
164100-53103	38	13 -3

Parts No.	Fig. No.	Ref. No.
164100-53104	38	13 -4
164100-53150	38	14
164100-53900	38	15
174307-51700	20	30
177070-03501	10	37
177088-02430	5	4
194250-51660	16	9
196420-02790	44	1
196420-09200	45	6
196420-09220	45	9
196440-09150	45	2
196440-09151	45	2 -1
196440-09160	45	3
196440-09170	45	4
196440-09180	45	5
196630-12980	5	5
22117-080000	25	16
22137-060000	16	23
22137-080000	37	7
22157-080000	33	14
22190-080002	12	16
		18
	23	13
	33	34
	36	5
22190-100002	20	66
22190-120002	20	79
	22	11
		32
	23	18
	36	13
22190-140002	46	18
22190-160002	11	4
	19	80
	36	12
22212-050000	25	15
	27	3
22217-050000	25	15 -1
	27	3 -1
	37	14
22217-060000	14	27
	19	81
	33	26
22217-080000	33	35
		36
	37	15
22217-120000	4	12
	19	93
22242-000100	25	6
22242-000120	6	34

Parts No.	Fig. No.	Ref. No.
22252-000220	10	21
22272-000030	20	67
22351-050010	19	82
22351-060012	6	23
22360-080000	25	7
22372-040000	20	80
22414-250150	25	7 -1
22512-040120	10	4
22724-800380	16	12
	29	27
22857-500100	6	51
		52
22857-500160	6	53
23000-013000	22	23 -1
	46	19
23000-016000	22	21
		23
	23	20
23000-025000	8	13
		25
	16	13
23000-028000	8	13 -1
		34
	16	16
23000-041000	16	10
23000-060000	7	6
23010-013000	15	25
23010-014000	24	5
23061-070300	15	26
23080-018000	12	20
23414-080000	14	14
	36	16
23414-120016	20	133
23414-170000	14	51
		51 -1
23418-060000	23	9
23854-100000	14	35
23857-030000	12	17
23857-060000	23	19
23857-080000	46	20
23857-100000	11	5
23876-005000	6	15
23876-010000	12	5
23876-030000	2	9
23887-100002	20	68
23887-180002	3	17
24101-060034	19	83
24101-063034	19	84
24311-000120	46	13
24311-000150	20	137

Parts No.	Fig. No.	Ref. No.
24311-000160	20	137 -1
24311-000320	2	30
	6	54
	36	6
24316-000150	19	85
24327-000600	12	7
	36	20
24341-000070	20	69
24341-000280	20	81
24341-000440	23	10
24357-240230	12	8
	36	21
25111-002000	41	30
26013-060162	23	14
26013-080142	10	38
26013-100302	4	5
26022-050122	19	86
26022-060162	19	87
26106-050102	19	88
26106-060102	12	12
	20	70
		82
	25	8
	33	15
26106-060122	2	22
	9	8
	14	48
	25	8 -1
	27	4 -2
26106-060142	20	83
	27	4 -1
26106-060162	2	23
	32	10
	33	16
26106-060202	6	55
	20	84
26106-060252	3	13
	14	28 -1
		28 -2
	33	17
26106-060282	3	14
	14	28
26106-060302	13	27
26106-060352	9	13
26106-060402	2	24
		25
26106-060452	3	15
	20	85
	27	4
26106-060602	2	26

Parts No. Index

Parts No.	Fig. No.	Ref. No.
26106-060602	3	16
26106-060652	2	27
26106-060752	6	56
26106-080122	7	7
	14	15
	33	4 -1
26106-080142	6	2
	33	4
26106-080162	10	40
		40 -1
	23	2
	32	11
	41	28
		31
26106-080202	13	28
	30	11
	31	26
	33	13
26106-080252	14	19
		37
		37 -1
		46
	30	12
	31	27
	37	8
26106-080302	46	21
26106-080354	32	16
26106-080402	6	36
	26	4 -1
26106-080422	26	4
26106-080452	3	20
26106-080502	14	16
26106-080652	14	20
26106-081152	15	20
26106-100252	4	6
		6 -1
	30	13
	31	28
26106-100302	12	9
	30	14
	31	29
	37	9
	46	22
26106-100322	28	1
		9
		14
26106-100402	37	10
26116-060652	16	19
26116-080604	37	11
26116-120302	29	24

Parts No.	Fig. No.	Ref. No.
26203-080302	8	26
26203-080402	8	14
26203-080452	8	14 -1
26203-080602	8	15
26203-080652	8	15 -1
26203-080802	8	27
26206-100252	3	7
26206-100302	3	10 -1
26216-080302	33	37
26216-080452	3	21
	26	5
26273-160151	45	8
26306-080002	2	28
26366-060002	32	12
26366-080002	3	22
	13	26
		29
	20	71
	26	6
	32	13
	33	38
		39
		40
	37	12
	41	32
	46	23
26366-100002	11	6
	46	24
26450-080282	28	15
26450-080302	28	15 -1
26557-050202	25	9
	27	5
26577-060122	14	9
26703-080002	8	4
26706-100002	28	2
		10
		16
26716-050002	37	16
26716-060002	19	89
26716-080002	37	13
		17
26716-120002	4	13
	19	94
26736-120002	20	86
26756-060002	20	87
26756-080002	28	3
	29	28
	37	17 -1
26793-080002	45	10
26979-050162	6	35

Parts No.	Fig. No.	Ref. No.
26986-080002	32	17
27233-250000	8	9
		21
27241-120000	1	13
27241-250000	14	10
27730-301400	25	13 -1
28210-000080	12	21
29621-200001	33	41
29622-250001	16	9 -1
		9 -2
41650-502320	46	11
41710-000380	25	13
41710-000410	25	10
	27	6
41730-000681	25	11
43662-015020	16	14
43662-015021	16	14 -1
43666-020951	16	15
45414-500260	28	11
46150-503100	14	24
48110-025063	28	6
48110-028063	28	7
48110-032411	28	4
48110-032502	28	8
48110-522361	28	5
719415-01560	1	1
719717-01500	2	5
719717-02900	1	14
719717-02910	1	34
719717-02911	1	34 -1
728790-51350	19	1
728790-92600	36	1
796420-08620	4	10
796420-09200	45	1
83213-003012	24	7
977780-01200	18	1
977780-01210	17	1
977780-01211	40	1
977780-01230	17	2
	18	2
977780-01240	18	3
977780-01250	17	3
977780-03000	17	9
	18	9
	40	9
X00141916	13	22 C
	41	25
X00183200	13	22 E
	41	27
X00190050	13	22 D

Parts No.	Fig. No.	Ref. No.
X00190050	41	26
X00353309	13	22 B
	41	24
X00370012	13	15
	41	15
X00371732	13	16
	41	16
X0044021509	17	7
	18	7
	40	7
X0145050	13	10
	41	10
X0146541	13	9
	41	9
X0146542	13	11
	41	11
X014678901	13	22 A
	41	23
X02173432	13	5
		12
	41	5
		12
X02173476	13	6
		19
	41	6
		19
X02233010	13	7
	41	7
X0318101004	40	2
X03431748	13	14
	41	14
X03431760	13	13
	41	13
X158606410X	40	3
X179100011X	18	5
X179100021X	17	5
X179100022X	40	5
X179100100X	17	6
	18	6
	40	6
X199903800X	17	8
	18	8
X199906101X	40	8
X2114535200	29	12
X6303BM0000	31	18
X8636008003	17	4
	18	4
X8636015001	40	4
XL150M14041	31	17
XL155G1330	31	8

Parts No. Index

Parts No.	Fig. No.	Ref. No.
XL180120000	31	4
XL1808320	31	13
XL180G13012	31	6
XL180G43150	31	7
XL180G61000	31	2
XL180G63006	31	5
XL180G85001	31	22
XL225431800	31	11
XL225G1325	31	9
XL235340110	31	16

Parts No.	Fig. No.	Ref. No.
-----------	----------	----------

Parts No.	Fig. No.	Ref. No.
-----------	----------	----------

Parts No.	Fig. No.	Ref. No.
-----------	----------	----------